



HEWLETT-PACKARD COMPANY / OPERATING AND SERVICE MANUAL

608C

**VHF SIGNAL
GENERATOR**

MANUAL CHANGES

MODEL 608C

VHF SIGNAL GENERATOR

Manual Serial Prefixed 010-
Manual Printed 1/61

To adapt this manual to instruments with other serial prefixes check for errata below, and make changes shown in tables.

Instrument Serial Prefix	Make Manual Changes	Instrument Serial Prefix	Make Manual Changes
010-03809 to 02665	2, 3 ERRATA		
202-04755 to 03810	1, 2, 3, ERRATA		

ERRATA

Table of Specifications:

Modulation Meter Accuracy should read: $\pm 10\%$ of full scale, 30% to 95% modulation.

Paragraph 4-13C:

Change line 3 to read: "exactly 1 milliwatt (0 dbm) on the external power meter".

Paragraph 4-14, Troubleshooting Chart: Step 1B, Change suggested Check and Remedy to read: "Check SWR or visually inspect attenuator".

Figure 4-16 (sheet 2 of 2): Change R115 in RF Oscillator Tuning Compartment to R116.

This resistor is connected across L2.

Table of Replaceable Parts, under MISCELLANEOUS:

Fuseholder: Change $\text{\textcircled{P}}$ Stock No. to 1400-0084

Table of Replaceable Parts: R60: Change to resistor, fixed, composition, 120 ohms $\pm 10\%$, 1/4 W, $\text{\textcircled{P}}$ Stock No. 0684-1211, Mfr 01121

R108, R112: Change to resistor: fixed, composition, 27 ohms $\pm 10\%$, 1/4 W,

$\text{\textcircled{P}}$ Stock No. 0684-2701, Mfr 01121

R109: Change to resistor: fixed, composition, 100 ohms $\pm 10\%$, 1/4 W,

$\text{\textcircled{P}}$ Stock No. 0684-1011, Mfr 01121

R110, R116: Change to resistor: fixed, composition, 47 ohms $\pm 10\%$, 1/4 W,

$\text{\textcircled{P}}$ Stock No. 0684-4701, Mfr 01121

R111, R113: Change to resistor: fixed, composition, 150 ohms $\pm 10\%$, 1/4 W,

$\text{\textcircled{P}}$ Stock No. 0684-1511, Mfr 01121

R115: Change to read: "Same as R1"

V9 Filament: Delete

Section IV, Page 16:

Change XV15, located between XV21 and XV13 to XV16.

CHANGE 1

I1: Change to lamp, incandescent: 250V, 10W, $\text{\textcircled{P}}$ Stock No. 2140-0007, Mfr 24455

R8: Change to resistor: fixed, composition, 680 ohms $\pm 10\%$, 1 W,

$\text{\textcircled{P}}$ Stock No. 0690-6811, Mfr 01121

CHANGE 2

V6: Tube electron: $\text{\textcircled{P}}$ Stock No. 1921-0001 may be marked 5675, HP4042, or 1921-0001.

V8: Tube, electron: $\text{\textcircled{P}}$ Stock No. 1921-0002 may be marked 5876, HP4043, or 1921-0002.

CHANGE 3

CR8 through CR11: Change to diode, silicon: $\text{\textcircled{P}}$ Stock No. 1901-0029

CR12 through CR15: Change to diode, silicon: $\text{\textcircled{P}}$ Stock No. 1901-0028

CERTIFICATION

THE HEWLETT-PACKARD COMPANY CERTIFIES THAT THIS INSTRUMENT WAS THOROUGHLY TESTED AND INSPECTED AND FOUND TO MEET ITS PUBLISHED SPECIFICATIONS WHEN IT WAS SHIPPED FROM THE FACTORY.

 FURTHER CERTIFIES THAT ITS CALIBRATION MEASUREMENTS ARE TRACEABLE TO THE NATIONAL BUREAU OF STANDARDS TO THE EXTENT ALLOWED BY THE BUREAU'S CALIBRATION FACILITY.



WARRANTY

All our products are warranted against defects in materials and workmanship for one year from the date of shipment. Our obligation is limited to repairing or replacing products (except tubes) which prove to be defective during the warranty period. We are not liable for consequential damages.

For assistance of any kind, including help with instruments under warranty, contact your authorized  Sales Representative for instructions. Give full details of the difficulty and include the instrument model and serial numbers. Service data or shipping instructions will be promptly sent to you. There will be no charge for repair of instruments under warranty, *except transportation charges*. Estimates of charges for non-warranty or other service work will always be supplied, if requested, before work begins.

CLAIM FOR DAMAGE IN SHIPMENT

Your instrument should be inspected and tested as soon as it is received. The instrument is insured for safe delivery. If the instrument is damaged in any way or fails to operate properly, file a claim with the carrier or, if insured separately, with the insurance company.

SHIPPING

On receipt of shipping instructions, forward the instrument prepaid to the destination indicated. You may use the original shipping carton or any strong container. Wrap the instrument in heavy paper or a plastic bag and surround it with three or four inches of shock-absorbing material to cushion it firmly and prevent movement inside the container.

GENERAL

Your authorized  Sales Representative is ready to assist you in any situation, and you are always welcome to get directly in touch with Hewlett-Packard service departments:

CUSTOMER SERVICE

Hewlett-Packard Company
395 Page Mill Road
Palo Alto, California, U.S.A.
Telephone: DAvenport 6-1755
Direct Dial Area Code 415
TWX No. PAL AL 117-U
Cable: "HEWPACK"

OR (In Western Europe)

Hewlett-Packard S.A.
Rue du Vieux Billard No. 1
Geneva, Switzerland
Telephone: (022) 26. 43. 36
Cable: "HEWPACKSA"



OPERATING AND SERVICING MANUAL



MODEL 608C VHF SIGNAL GENERATOR

SERIALS PREFIXED: 010 -



SPECIFICATIONS

Frequency Range:	10 mc to 480 mc in 5 bands.
Tuning Control:	Frequency control mechanism provides a main dial calibrated in megacycles and a vernier dial for interpolation purposes. Total Scale Length: Approximately 45 inches. Calibration: Every other megacycle 130 to 270 mc; every 5 mc above 270 mc.
Vernier Control:	A separate vernier control allows variations of about ± 25 kc (at high frequencies) to provide precise frequency setting for sensitivity checks of extremely selective receivers.
Frequency Calibration Accuracy:	Within $\pm 1\%$ over entire frequency range.
Resettability:	Better than $\pm 0.1\%$ after initial instrument warm-up.
Frequency Drift:	Less than 0.005% over a 10 minute interval after initial instrument warm-up (15°C to 35°C ambient). When frequency is changed by dial, instrument must restabilize one minute for each 10% frequency change. When frequency is changed by bandswitching, 10 minutes are required to restabilize.
Output Level:	0.1 microvolt to 1.0 volt (into a 50-ohm resistive load). Attenuator dial calibrated in volts and dbm. (0 dbm equals 1 milliwatt in 50 ohms.)
Output Voltage Accuracy:	± 1 db over entire frequency and attenuation range (into a 50 ohm resistive load).
Generator Impedance:	50 ohms, maximum swr 1.2
Internal Modulation Frequencies:	400 cps $\pm 10\%$ and 1000 cps $\pm 10\%$
External AM Modulation:	From 0 to 95% at output levels of 0 dbm and below from modulation frequencies 20 cps to 20 kc. Input requirements, 0.5 volt rms across 15K ohms.
Modulation Meter Accuracy:	$\pm 10\%$ of reading 30% to 95% modulation.
Envelope Distortion:	Less than 5% at 30% sine-wave modulation and less than 10% at 50% sine-wave modulation.

SPECIFICATIONS (CONT'D.)

External Pulse Modulation: Positive 5 volt peak pulse required. 40 mc to 220 mc; combined rise and decay time of rf pulse less than 4 microseconds. 220 mc to 420 mc; combined rise and decay time of rf pulse less than 1 microsecond.
Residual level at least 20 db below 1 volt peak pulse output.

Incidental Frequency Modulation: Less than 0.0025% at 30% amplitude modulation for rf output frequencies from 21 to 480 mc.

Leakage: Negligible; permits receiver sensitivity measurements down to at least 0.1 microvolt.

Power: 115/230 volts $\pm 10\%$, 50-1000 cps, approximately 220 watts.

Dimensions: Cabinet Mount: 13-1/4 in. wide, 16-3/8 in. high, 21 in. deep.

Rack Mount:

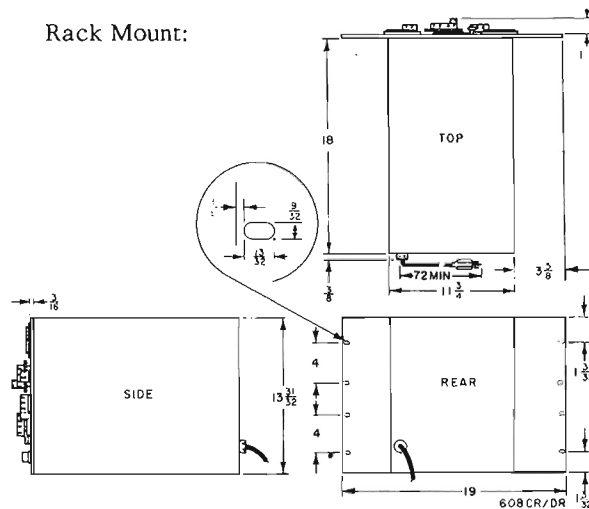

Weight: Cabinet Mount: Net 62 lbs, shipping 88 lbs.
Rack Mount: Net 62 lbs, shipping 91 lbs.

Accessories Available: $\text{\textcircled{P}}$ 608A-16D Output Cable provides 50 ohm termination and standard binding posts at the end of a 24 inch length of cable. Allows direct connection of the signal generator to high impedance circuits.
 $\text{\textcircled{P}}$ 608A-95A Fuse Holder provides protection of the attenuator elements when the 608 is used for transceiver tests.

CONTENTS

SECTION I	GENERAL DESCRIPTION	
1 - 1	Introductory	I - 1
1 - 2	Auxiliary Equipment	I - 1
1 - 3	General Electrical Characteristics	I - 1
1 - 4	Supply Voltage	I - 2
1 - 5	Power Cable	I - 2
1 - 6	Physical Description	I - 2
1 - 7	Inspection	I - 2
SECTION II	INSTALLATION AND OPERATION	
2 - 1	Introductory	II - 1
2 - 2	General	II - 1
2 - 3	Installation	II - 1
2 - 4	Operating Controls, Dials, and Terminals	II - 1
2 - 5	Turning On the Equipment	II - 1
2 - 6	Continuous Wave Operation	II - 3
2 - 7	Internal Sine Wave Modulation	II - 4
2 - 8	External Sine Wave Modulation	II - 4
2 - 9	Pulse Modulation	II - 5
2 - 10	Signal Generator Loading Considerations	II - 5
2 - 11	Considerations for Pulse-Modulated R-F Output	II - 6
SECTION III	THEORY OF OPERATION	
3 - 1	General	III - 1
3 - 2	R-F Generator Assembly	III - 3
3 - 3	Radio Frequency Oscillator	III - 3
3 - 4	Radio Frequency Power Amplifier	III - 5
3 - 5	Output Attenuator and R-F Power Monitor	III - 6
3 - 6	Modulator Section	III - 7
3 - 7	Modulation-Measuring Circuits	III - 9
3 - 8	Power Supply	III - 11
3 - 9	Heater Supply Multivibrator	III - 12
SECTION IV	MAINTENANCE	
4 - 1	Introduction	IV - 1
4 - 2	Cabinet Removal	IV - 1
4 - 3	Periodic Checks and Routine Care	IV - 1
4 - 4	Test Equipment and Special Tools Required	IV - 3
4 - 5	Localizing Trouble	IV - 4
4 - 6	Replacement of Electron Tubes	IV - 4
4 - 7	Radio Frequency Oscillator Tube Replacement	IV - 5
4 - 8	Radio Frequency Amplifier Tube Replacement	IV - 5
4 - 9	Replacement of Electron Tubes within the Regulated Power Supplies	IV - 7
4 - 10	Attenuator Probe Replacement	IV - 7
4 - 11	Replacement of Lamp I1	IV - 10
4 - 12	Calibration of the Percent Modulation Meter	IV - 10
4 - 13	Output Volts Meter Calibration and R-F Power Monitor Service	IV - 11
4 - 14	Trouble Shooting Chart	IV - 13
SECTION V	TABLE OF REPLACEABLE PARTS	
5 - 1	Table of Replaceable Parts	V - 1

SECTION I

GENERAL DESCRIPTION

1-1 INTRODUCTORY

The Hewlett-Packard Model 608C VHF Signal Generator is a general purpose test instrument which furnishes accurately adjustable r-f signals from 0.1 microvolt to 1 volt over the frequency range from 10 to 480 megacycles. The output signal may be amplitude modulated by internally generated sine waves or by externally applied sine waves or pulses. The output signal level is adjustable by an attenuator calibrated in both volts and dbm and can be read directly to an accuracy of ± 1 db over the full frequency and attenuation range without the use of external pads, monitoring devices, or charts. The 608C features a very wide frequency range, high output, and straightforward operation through the use of reliable, direct-reading controls and meters.

The Model 608C Signal Generator is designed for general applications in the 10- to 480-megacycle frequency range, such as testing, calibrating, and trouble shooting VHF radio equipment and circuits. In conjunction with other test equipment, the 608C is useful for measuring standing wave ratios, antenna and transmission line characteristics, receiver sensitivity, etc. To obtain best accuracy in these applications, care has been taken to hold spurious modulation from the generator to a very low value.

1-2 AUXILIARY EQUIPMENT

SUPPLIED -

The special wrench necessary for removing the r-f amplifier tube. It is mounted on the instrument chassis.

AVAILABLE -

Ⓢ 608A-95A Fuseholder. To protect the output attenuator from damage, for some applications (such as transceiver testing) it is desirable to insert a fuse between the 608C and external equipment. The 608A-95A is a special coaxial fuseholder which houses

a type 8AG, 1/16 amp. fuse which protects the output attenuator from damage in the event that an external voltage is accidentally applied to the RF OUTPUT connector. The fuseholder has an insertion loss of 0.50 db at 200 mc, 0.56 db at 300 mc, and 0.65 db at 400 mc; its swr is not greater than 1.35 when connected to a 50 ohm resistive load.

Ⓢ 608A-16D Terminated Output Cable. This cable assembly provides a 50-ohm termination and standard binding posts at the end of a 40-inch length of cable. The 608A-16D allows direct connection of the 608C to a high-impedance circuit.

1-3 GENERAL ELECTRICAL CHARACTERISTICS

The Model 608C Signal Generator furnishes a continuously adjustable r-f output signal from 10 to 480 megacycles. The frequency is indicated on a drum-type dial calibrated to be read directly in megacycles with a maximum error of $\pm 1\%$. A short range incremental tuning device is provided for making extremely small changes in the output signal frequency. The fine frequency tuner is operated from the front panel by a small knob to the left of the main **FREQ.** control knob.

An output attenuator, calibrated to be read directly in volts and decibels to an accuracy of ± 1 db or better over the entire attenuation and frequency range, varies the output signal from +7 dbm to -127 dbm (500 millivolts to 0.1 microvolt) when connected to an external 50-ohm resistive load. The internal impedance of the generator, as seen at the output jack, is nominally 50 ohms over the full frequency range; and when connected to a 50-ohm resistive load, the vswr due to mismatch will not be greater than 1.2 (swr of 1.6 db).

The r-f output from the 608C may be sine wave amplitude modulated from either an internal 400 or 1000 cps r-c oscillator or with an external signal 20 to 20,000 cps with an amplitude of at least 0.5 volt. All sine wave modulation is continuously adjustable from 0 to 95% by a front panel control. The percent modulation is continuously monitored

and indicated on a front panel modulation meter calibrated directly in percent modulation. Calibration accuracy is better than $\pm 10\%$ of the meter reading at modulation percentages between 30% and 95%.

The envelope of a sine wave modulated signal contains less than 5% distortion. Incidental amplitude modulation of the cw output signal is less than 0.1%. The level of any harmonic or spurious signal contained in the cw output signal is 40 decibels below the level of the output signal when the output level is greater than 200 microvolts.

The 608C may be pulse modulated from an external source of positive pulses of at least 5 volts amplitude. R-f output pulses have a combined rise and decay time as short as 4 μsec at 40 mc, 2 μsec at 100 mc, and less than 1 μsec above 200 mc.

The Model 608C is suitable for aligning narrow-band a-m receivers. In such applications a significant amount of spurious f-m in the generator usually results in misalignment of the receiver because the selectivity characteristics of the receiver has the ability to detect the f-m. To keep spurious f-m to a negligible value (less than 0.0025% at 30% modulation for frequencies above 21 megacycles), the instrument employs a master oscillator-power amplifier (MOPA) type of r-f generator circuit. Modulation is introduced at the power amplifier stage and has a very little effect on the frequency of the oscillator.

To minimize r-f leakage, all r-f signal circuits are housed in an aluminum casting. Leakage is such that when the output signal is adjusted for 0.1 microvolts, the conducted signal leakage at any other front panel connector and the radiated leakage two inches from the instrument are each less than 1.0 microvolt.

All plate circuits in the instrument are operated from regulated d-c voltage. In addition, the heaters in the r-f oscillator and power amplifier tubes are operated from regulated square wave power generated by a multivibrator to enhance the stability of the system. The instrument is designed to operate from a nominal 115/230-volt, 50- to 400-cycle, single-phase a-c power source and consumes approximately 150 watts.

Further information is given in the Table of Specifications at the beginning of this manual.

1-4 SUPPLY VOLTAGE

The 608C, like other $\text{\textcircled{P}}$ instruments, is normally shipped from the factory with the dual 115 volt primary windings of the power transformer connected

in parallel. If operation from a 230 volt source is desired, the windings may be quickly reconnected in series. Refer to the schematic drawing at the rear of the manual. Remove the jumpers from terminals 1-4 and 2-5. Connect a jumper between terminals 4-5. Replace the 3.2 ampere slow blow fuse with a 1.6 ampere slow blow fuse.

1-5 POWER CABLE

The three conductor power cable supplied with this instrument is terminated in a polarized three prong male connector recommended by the National Electrical Manufacturers' Association. The third contact is an offset round pin added to a standard two blade connector which grounds the instrument chassis when used with an appropriate receptacle. To use this connector in a standard two-contact receptacle, an adapter should be used to connect the NEMA connector to the two contact system. When the adapter is used, the third contact is terminated in a short lead from the adapter which can then be connected to the (grounded) connector mounting box in order to ground the instrument chassis.

1-6 PHYSICAL DESCRIPTION

The 608C is 13-3/4 inches wide by 16-1/4 inches high by 21 inches deep and weighs 63 pounds. The instrument is housed in an aluminum cabinet finished in gray baked enamel. Guard-rail type handles are provided to assist in handling and to protect the front panel controls.

All r-f signal circuits and the output attenuator are housed in an aluminum die casting divided into three compartments. For ease in r-f tube replacement, the two r-f tubes are located in the uppermost compartment, separate from the tuned circuits. This compartment is accessible by removing the small plate under the frequency dial drum. The compartments containing the tuned circuits are accessible when the side plate is removed.

All controls, meters, and terminals are located on the front panel and are marked with large, white-filled, engraved letters. The frequency dial is of the drum type with a scale length of 11-1/2 inches for each band, or approximately 57 inches for the entire range. The full frequency range is covered in five bands, each band being read on a separate dial scale. A pointer, automatically positioned, indicates the scale in use.

1-7 INSPECTION

Refer to the warranty sheet in this manual.

SECTION II

INSTALLATION AND OPERATION

2-1 INTRODUCTORY

This section contains instructions for installing and operating the Model 608C VHF Signal Generator. The information contained in this section is as follows:

- 2-2 General
- 2-3 Installation
- 2-4 Operating Controls, Dials, and Terminals
- 2-5 Turning On the Equipment
- 2-6 Continuous Wave Operation
- 2-7 Internal Sine Wave Modulation
- 2-8 External Sine Wave Modulation
- 2-9 Pulse Modulation
- 2-10 Signal Generator Loading Considerations
- 2-11 Considerations for Pulse Modulated RF Output

2-2 GENERAL

The Model 608C generates a radio frequency signal from 0.1 microvolt to 1 volt over the frequency range from 10 to 480 megacycles. The r-f output signal may be modulated by internally generated sine waves at 400 and 1000 cps or by externally developed sine waves or pulses with modulation percentage being indicated on a direct-reading front panel meter. The generator is designed to operate into a resistive load of 50 ohms; and when so loaded, the output voltage and power may be read directly from the output attenuator dial in conjunction with a front panel output level meter.

2-3 INSTALLATION

Since the 608C is a portable equipment designed for test-bench use and not for permanent installation, no special installation procedure is necessary. Both the signal generator and the equipment under test should be within arm's reach of the operator, with connecting leads between the equipments kept as short as possible.

CAUTION: Do not obstruct the ventilating louvers on the sides of the instrument cabinet. Safe oper-

ating temperature depends on free air flow through these louvers.

When the signal generator is to remain idle for extended periods of time, it is desirable to store the instrument in a place that will prevent moisture and dust from entering the cabinet and also prevent possible damage to front panel jacks and cabinet.

2-4 OPERATING CONTROLS, DIALS, AND TERMINALS

The front panel operating controls, dials, and terminals for the 608C are listed with their functions in Figure 2-1. A simplified block diagram showing which circuits are affected by various front panel controls is shown in Figure 2-2.

2-5 TURNING ON THE EQUIPMENT

To place the signal generator into operation, proceed as follows:

- a. With power switch in "off" position, connect the power cord to the power source.
- b. Place the MOD. SELECTOR in the CW position and the OUTPUT LEVEL control 75% of full clockwise rotation. Other controls may be set in any position before turning generator on.
- c. Turn power switch to the ON position. The POWER pilot lamp should indicate that power is applied to all circuits of the signal generator.
- d. After approximately 1 minute warm-up adjust the AMP. TRIMMER for maximum reading and OUTPUT LEVEL control to obtain a SET LEVEL reading on the front panel OUTPUT VOLTS meter.
- e. Allow equipment to heat for 5 minutes before use. If greatest frequency stability is required, allow equipment to heat for 45 minutes.

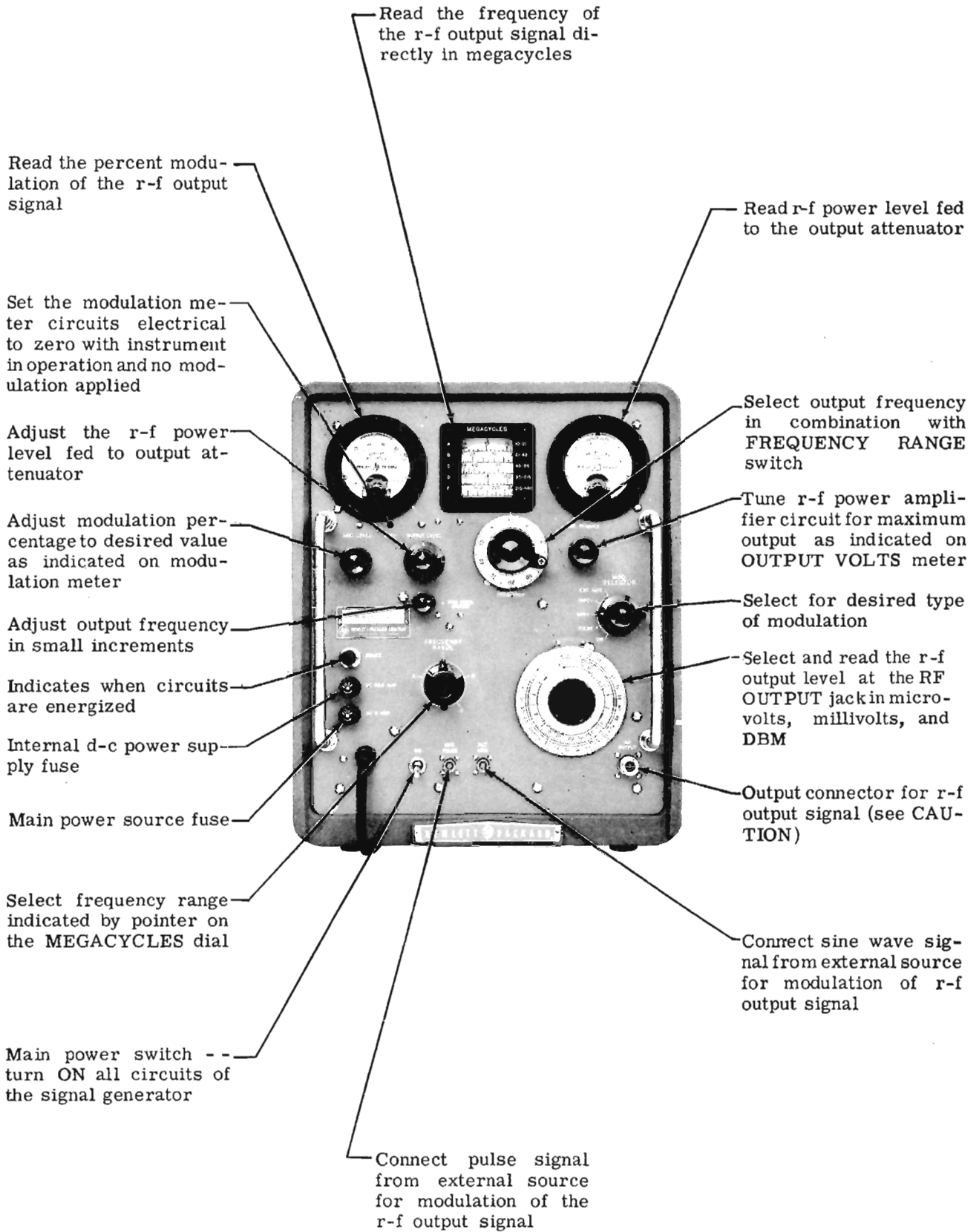

Figure 2-1. Model 608C Front Panel Controls

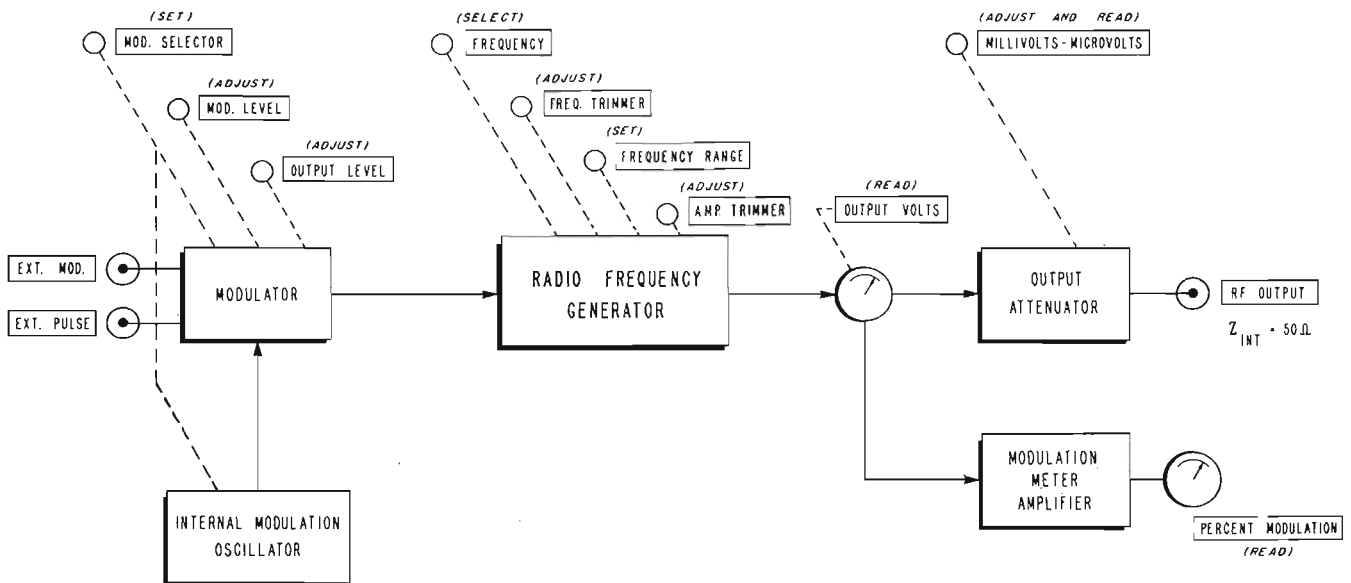

Figure 2-2. Diagram Showing Relationships of Front Panel Controls to Major Circuits

CAUTION: Do not connect any source of r-f or d-c power to the RF OUTPUT jack on the Model 608C Signal Generator. To do so will burn out the impedance-matching network in the output attenuator. Special care must be taken when working with "transceiver" type equipments to insure that the transmitter remains inoperative while the signal generator is connected to the equipment antenna connector.

NOTE: To protect the output attenuator, a special fuseholder (Ⓢ Stock No. 608A-95A) is available for connection to the RF OUTPUT jack. Where there is the possibility of voltage being applied to the RF OUTPUT jack, this fuse should be used between the output jack and external equipment.

2-6 CONTINUOUS WAVE OPERATION

GENERAL -

When 608C is set for CW operation, the PERCENT MODULATION meter may have momentary fluctuations due to switching transients.

STEP-BY-STEP PROCEDURE FOR OBTAINING CW OPERATION -

- a. Following the "turning on" procedure described in paragraph 2-5, set the MOD. SELECTOR to CW.
- b. Select the desired band of frequencies with the FREQUENCY RANGE selector.
- c. Set the FINE FREQUENCY ADJ. control knob so that the white dot on the knob is aligned with the white dot on the front panel.
- d. Set the MEGACYCLES dial to the desired frequency.
- e. Set the OUTPUT LEVEL control to near maximum.
- f. Adjust the AMP. TRIMMER for maximum output as indicated on OUTPUT VOLTS meter.
- g. Connect the external load to the RF OUTPUT jack on the signal generator. (See preceding CAUTION.)

- h. Set the OUTPUT LEVEL control to obtain a reading at SET LEVEL on the OUTPUT VOLTS meter.
- i. Set the output attenuator for the desired output level as read directly from the output attenuator dial.
- j. If it is desired to shift the output frequency very accurately by small amounts, readjust the FINE FREQUENCY ADJ. control knob to obtain the exact desired output.

NOTE: The MEGACYCLES dial calibration is most accurate when the white dot on the FINE FREQUENCY ADJ. knob is aligned with the white dot on the panel (minimum capacity).

2-7 INTERNAL SINE WAVE MODULATION

GENERAL -

For internal sine modulation of the r-f output signal, the 608C supplies the same quality r-f signal as is obtained for cw operation and which may be modulated by either 400- or 1000-cycle internally generated sine waves selected by the MOD. SELECTOR switch. The modulating frequencies are accurate to within $\pm 5\%$ and envelope distortion of the modulated carrier is less than 5% for modulation percentages to 30%; 10% at 50% modulation.

The degree of modulation is continuously adjustable from 0 to 95% by the MOD. LEVEL control and is indicated on the PERCENT MODULATION meter to an accuracy of $\pm 10\%$ of the meter reading from 30% to 95%. Incidental frequency modulation resulting from amplitude modulation of the output signal is held very low. Output frequency and power level are set in the same manner as for cw operation except that the MOD. SELECTOR is set to 400 or 1000.

STEP-BY-STEP PROCEDURE FOR OBTAINING INTERNAL MODULATION -

- a. Follow complete step-by-step procedure for obtaining cw operation.
- b. Adjust the PERCENT MODULATION meter electrical zero if needed, by inserting a small screwdriver through the front panel hole labeled ZERO and turning the control to bring the pointer to zero. The MOD. LEVEL control should be set

to full counter clockwise and the instrument operated for at least 5 minutes before this adjustment is made.

- c. Set the MOD. SELECTOR to 400 or 1000 as desired.
- d. Set the MOD. LEVEL control for desired degree of modulation as indicated on the PERCENT MODULATION meter.
- e. Subsequent changes may be made in the frequency dial and output attenuator settings while instrument is being operated with modulation.

NOTE: When adjusting the OUTPUT VOLTS meter with the OUTPUT LEVEL control, it is best first to reduce the MOD. LEVEL control to zero. After the r-f output has been adjusted to the desired value and the AMP. TRIMMER adjusted for peak output, the MOD. LEVEL control is advanced in a clockwise direction until the PERCENT MODULATION meter indicates the desired degree of modulation.

It may be noticed that when the percent modulation is increased to very high levels there will be a resulting increase in the reading of the OUTPUT VOLTS meter. The OUTPUT LEVEL control should be reset to maintain a reading at SET LEVEL on the OUTPUT VOLTS meter.

2-8 EXTERNAL SINE WAVE MODULATION

GENERAL -

An external signal source generating frequencies from 20 to 20,000 cycles per second with an amplitude above .5 volts may be used to modulate the r-f output signal from the signal generator. The degree of modulation is also continuously adjustable by means of the MOD. LEVEL control and is indicated directly on the front panel PERCENT MODULATION meter. The modulating signal is applied through an appropriate cable to the EXT. MOD. jack on the front panel. The input impedance at the EXT. MOD. jack is approximately 50,000 ohms.

STEP-BY-STEP PROCEDURE FOR OBTAINING EXTERNAL MODULATION -

- a. Follow complete step-by-step procedure for obtaining cw operation.
- b. Set MOD. SELECTOR to EXT. MOD. position.

- c. Connect modulating source to EXT. MOD. jack.
- d. Set MOD. LEVEL control for desired degree of modulation as read on the PERCENT MODULATION meter.
- e. Subsequent changes may be made in frequency dial and output attenuator settings while the instrument is being operated with modulation.

NOTE: It may be noticed that when the percent modulation is increased to very high levels there will be a resulting increase in the readings of the OUTPUT VOLTS meter. The OUTPUT LEVEL control should be reset to maintain a reading at SET LEVEL on the OUTPUT VOLTS meter.

2-9 PULSE MODULATION

GENERAL -

An external pulser generating positive pulses from 10 to 50 volts in amplitude may be used to modulate the r-f output signal from the 608C Signal Generator. The resultant r-f output pulse from the signal generator is of good quality at r-f frequencies above 100 megacycles, is free of transients, and has low residual signal between pulses. For pulse operation the signal generator produces essentially no r-f output signal until an external positive pulse is applied to the EXT. PULSE jack. The amplitude of the modulation pulse is not adjustable by the MOD. LEVEL control. Any pulse of 10 volts amplitude or better will 100% modulate the r-f output signal, the peak of the r-f output pulse being within 1 db of the cw level established by the same settings of the OUTPUT LEVEL control and output attenuator.

STEP-BY-STEP PROCEDURE FOR OBTAINING PULSE-MODULATED OUTPUT -

- a. Follow complete step-by-step procedure for obtaining cw operation.
- b. Set the MOD. SELECTOR to the PULSE position.
- c. Connect modulating source to EXT. PULSE jack on front panel.

2-10 SIGNAL GENERATOR LOADING CONSIDERATIONS

When using the Model 608C, the external load connected to the instrument should be 50 ohms resistive for best accuracy of indicated output power.

The output attenuator dial has been calibrated by using a resistive load of 50 ohms. The internal impedance of the generator is sufficiently close to 50 ohms so that in the worst case a vswr of only 1.2 (swr 1.6 db) exists when the generator is measured from an external signal source of 50 ohms. Error in power level indication with this magnitude of vswr will have no important effect on the accuracy of the output attenuator dial. However, if the value of the load is not known and if best accuracy in measurements is desired, it is necessary that the standing wave ratio in the line to the load be minimized.

Table 2-1 shows the calculated power loss when the load on the signal generator causes a voltage standing ratio of the magnitudes shown. The vswr values shown are actually a comparison between a load and a 50-ohm transmission line. Mismatches causing the voltage standing wave ratios given in the left-hand column will give power losses somewhere between the limits shown in the remaining two columns. The minimum loss figures in columns 2 and 3 assume a mismatch of 1.2 vswr between the signal generator and transmission line, the minimum loss being indicated in column 2, maximum loss in column 3. The maximum loss shown is the total loss from the maximum power available from the generator for a given setting of the output attenuator and includes the possible generator vswr of 1.2. The data does not allow for losses in the transmission line to the load, for in most cases such losses are sufficiently small so that they are not of importance.

It will be seen that when the load is matched to the transmission line the loss from the maximum power available from the signal generator is approximately 0.06 db in the worst case. Although the losses as shown in db do not consist of large numerical values, it should be noted on the attenuator dial that they may represent a considerable change in the voltage calibration so far as the voltage impressed across the external load is concerned.

In most cases when making measurements on receivers designed to work from a 50-ohm line and antenna, the standing wave ratio in the line from the signal generator to the receiver is not significant. The reason for this is that any power reflected from the receiver back towards the generator represents a deficiency in receiver design, and the amount of power lost in such cases is considered as a loss subtractive from the gain of the receiver. A sometimes overlooked factor which contributes error in high-frequency measurements is the improper assembly of coaxial connectors. A standing wave ratio of several db with attendant error can often be attributed to this cause.

Table 2-1. Power Losses as Related to VSWR in Generator Load

VSWR in 50-ohm Line	Min. Power Loss	Max. Power Loss
1.0	.06 db	.06 db
1.5	.08 db	.37 db
2.0	.3 db	.85 db
2.5	.6 db	1.3 db
3.0	.9 db	1.7 db
4.0	1.5 db	2.4 db
5.0	2.0 db	3.1 db

2-11 CONSIDERATIONS FOR PULSE-MODULATED R-F OUTPUT

Because the bandwidth of the tuned r-f amplifier circuit increases as frequency is increased, the rise and decay times of high speed pulses decrease as the signal generator output frequency is increased. The following table lists the approximate minimum pulse widths that may be expected at the upper and lower frequency limits of the B, C, D, and E frequency bands.

Frequency bands	Combined rise and decay	Min. pulse width for output pulse equal to CW level ± 1 db
B band	2 to 5 μ sec	1-1/2 to 4 μ sec
C band	1-1/2 to 4 μ sec	1-1/4 to 3 μ sec
D band	3/4 to 2 μ sec	3/4 to 2 μ sec
E band	1/2 to 1 μ sec	1/2 to 1 μ sec

SECTION III

THEORY OF OPERATION

3-1 GENERAL

The electrical circuits of the Model 608C Signal Generator are divided into the sections shown in the block diagram in Figure 3-1, plus a power supply which is not shown.

The operation of the various sections is as follows:

- a. The radio frequency oscillator generates the r-f signal which is fed through a power amplifier to the output jack of the signal generator. The oscillator is of the Colpitts type and provides a continuously variable sine wave signal of high stability.
- b. The radio frequency power amplifier receives both the r-f and modulation signals and ampli-

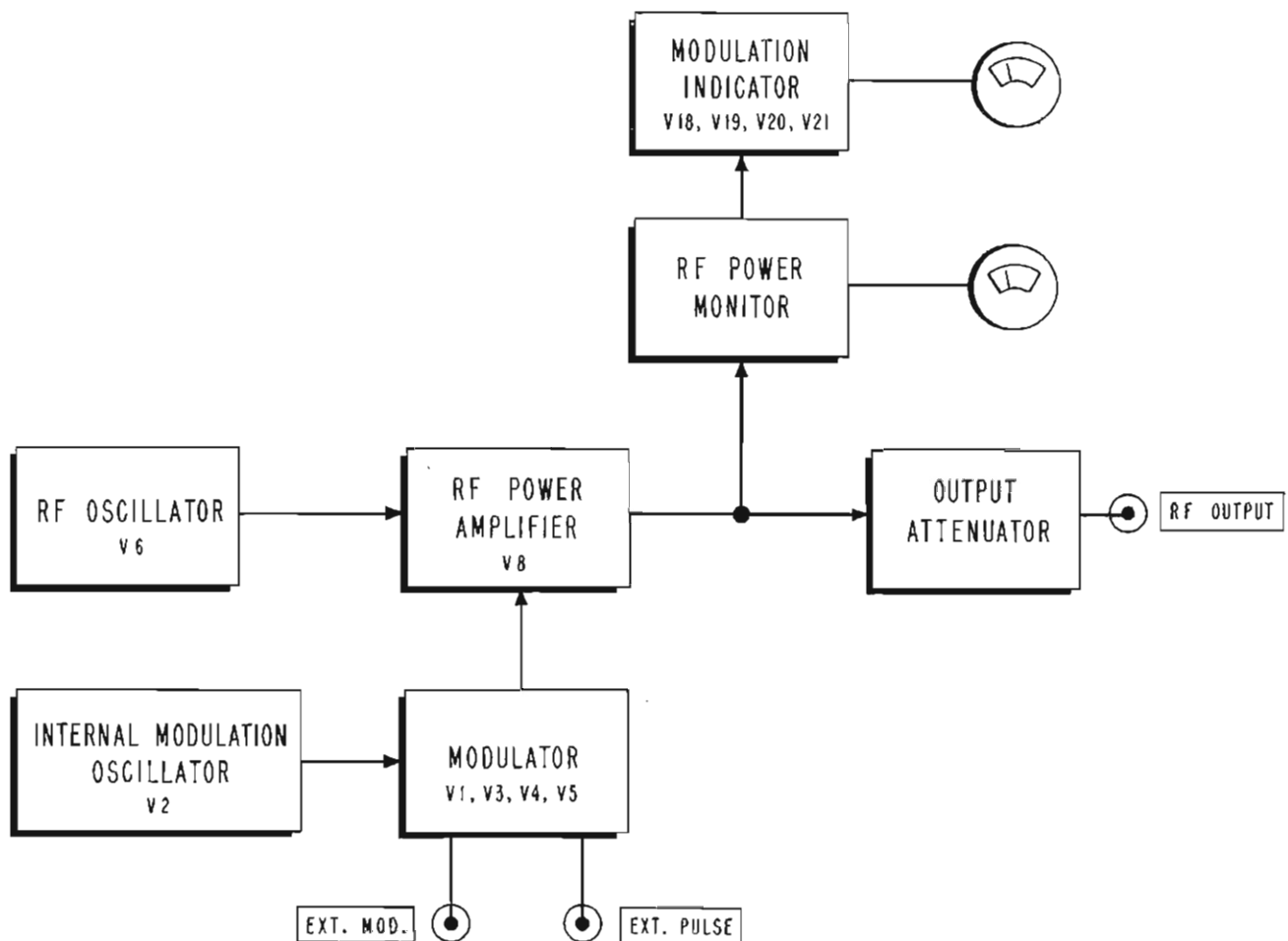
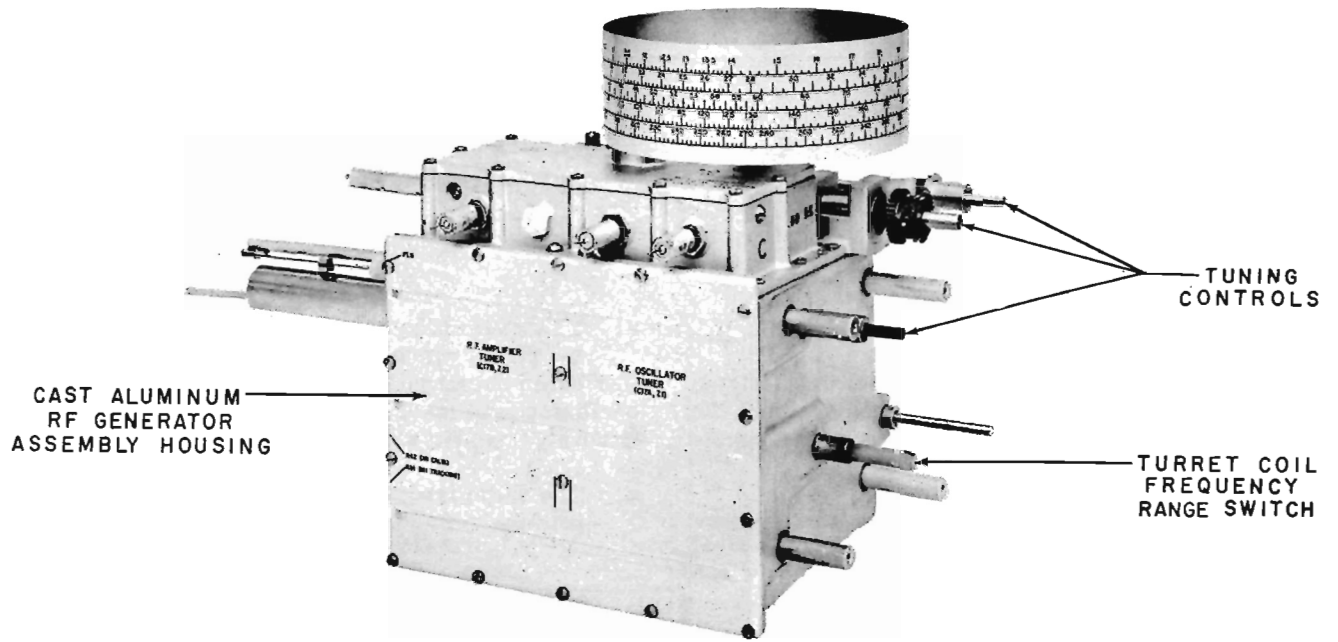
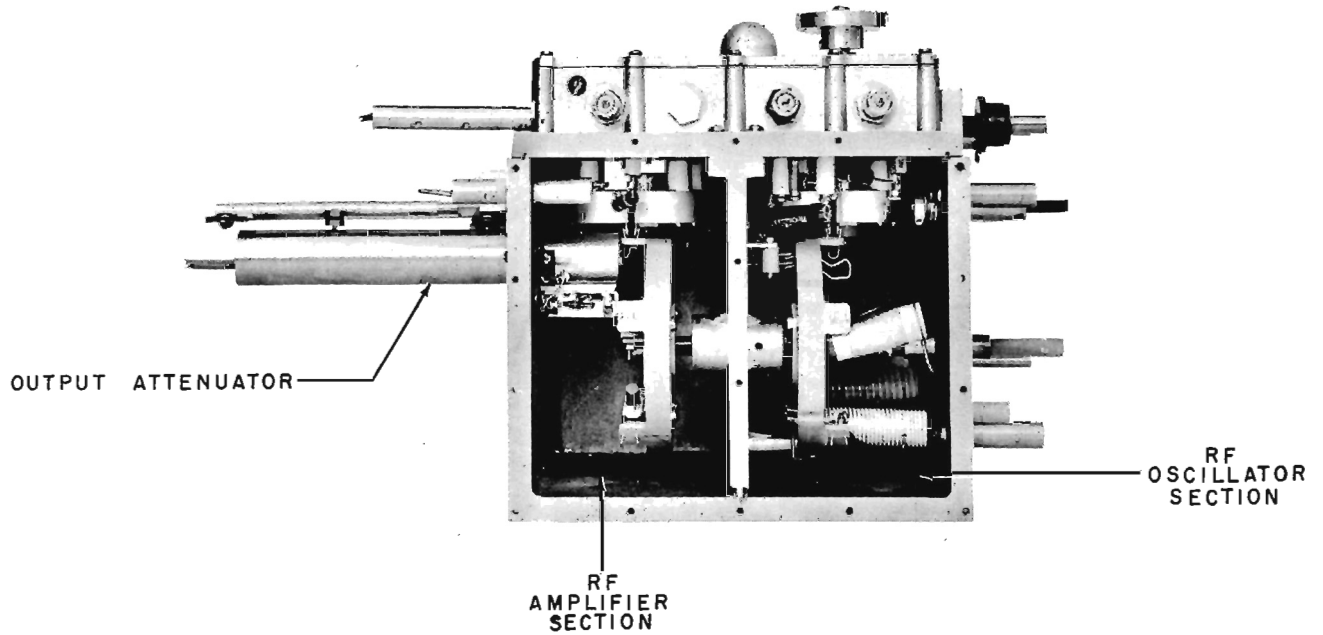

Figure 3-1. Block Diagram for Model 608C



a) Cover Plate Attached



b) Cover Plate Removed

Figure 3-2. R-F Generator Assembly

fies the r-f energy for application to the output attenuator. The r-f amplifier also receives variable bias from the modulator which permits adjustment of the power level fed to the output attenuator.

- c. The output power monitor samples the r-f energy fed to the output attenuator and indicates the power and voltage level on a front panel meter.
- d. The output attenuator obtains monitored r-f energy from the power amplifier, applies the selected degrees of attenuation, and conducts the energy to the front panel output jack.
- e. The internal modulation oscillator generates either a 400 or 1000 cycle-per-second sine wave for application to the modulation system.
- f. The modulator receives all signals for application to the r-f power amplifier and also supplies variable bias to the r-f amplifier for control of the r-f output level.
- g. The modulation-measuring circuits receive detected modulation from the r-f power monitor, amplify and rectify it, and indicate the modulation percentage directly on a front panel meter.

3-2 R-F GENERATOR ASSEMBLY

The r-f generator assembly, shown in Figure 3-2, is the heart of the Model 608C, generating the r-f energy that is delivered to the external load. This assembly houses an MOPA circuit consisting of a Colpitts oscillator, power amplifier, and a piston-type output attenuator. To hold both radiated and conducted r-f leakage to a minimum, the radio frequency circuits of the generator are enclosed in a cast aluminum housing, with all electrical connections to the internal circuits being made through special r-f filters.

3-3 RADIO FREQUENCY OSCILLATOR

The radio frequency oscillator generates a sine wave signal from 10 to 480 megacycles in five frequency bands, each band having approximately a 2:1 frequency range. A type 5675 "pencil" triode tube is used in a Colpitts circuit tuned by a precision split-stator capacitor and five separate r-f transformers, L1 through L5. The tuning capacitor, which is specially constructed for high stability and resetability, consists of two stator sections connecting to the grid and plate of the oscillator tube and a floating rotor which meshes equally between the two stators. The tuning capacitor assembly, mounted inside and at the top of the oscillator tuning compartment in the generator housing, is driven

by a ball-bearing mounted worm drive through the top of the housing.

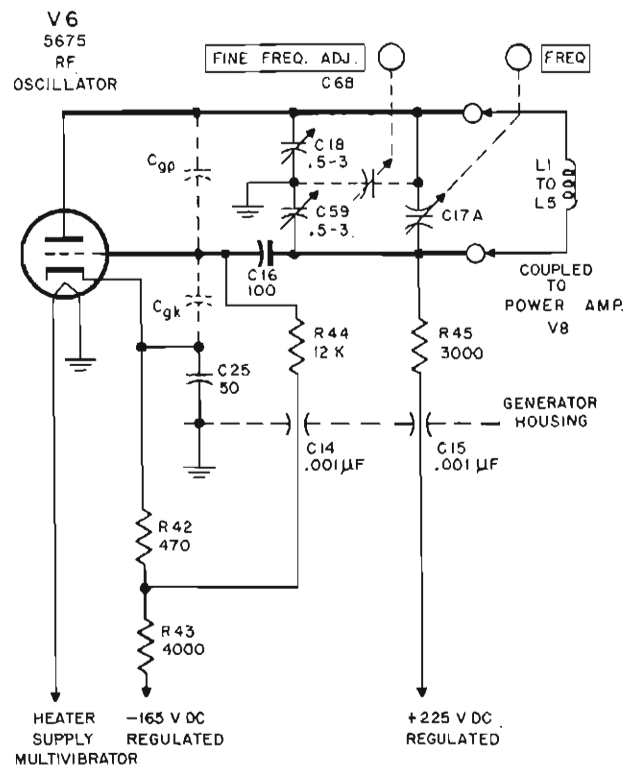

Figure 3-3. Schematic Diagram of Radio Frequency Oscillator

The tuned inductors for the A, B, and C bands are precision wound under tension on ceramic forms while for the D and E bands the inductors consist of silver-plated Nilvar bar loops. The inductors are mounted on a revolving turret actuated by the FREQUENCY RANGE selector. As the turret is rotated, the desired coil is positioned in the tuned circuit just below the oscillator tuning capacitor, connections being made through large silver-plated contacts mounted directly on the bottoms of the two stators of the tuning capacitor. Both ends of the tuning inductor and capacitor are at r-f and d-c potential, with no part of this circuit grounded.

The fine frequency tuner consists of a small metal disk mounted off center at the end of a bakelite control shaft (see Figure 3-4). The shaft is mounted level with the oscillator tuning capacitor about 1/2" away. As the shaft is turned, the disk moves closer or farther away from the tuning capacitor to increase and decrease the capacity in the tuned circuit. The change occurs over 180° rotation of the knob. When

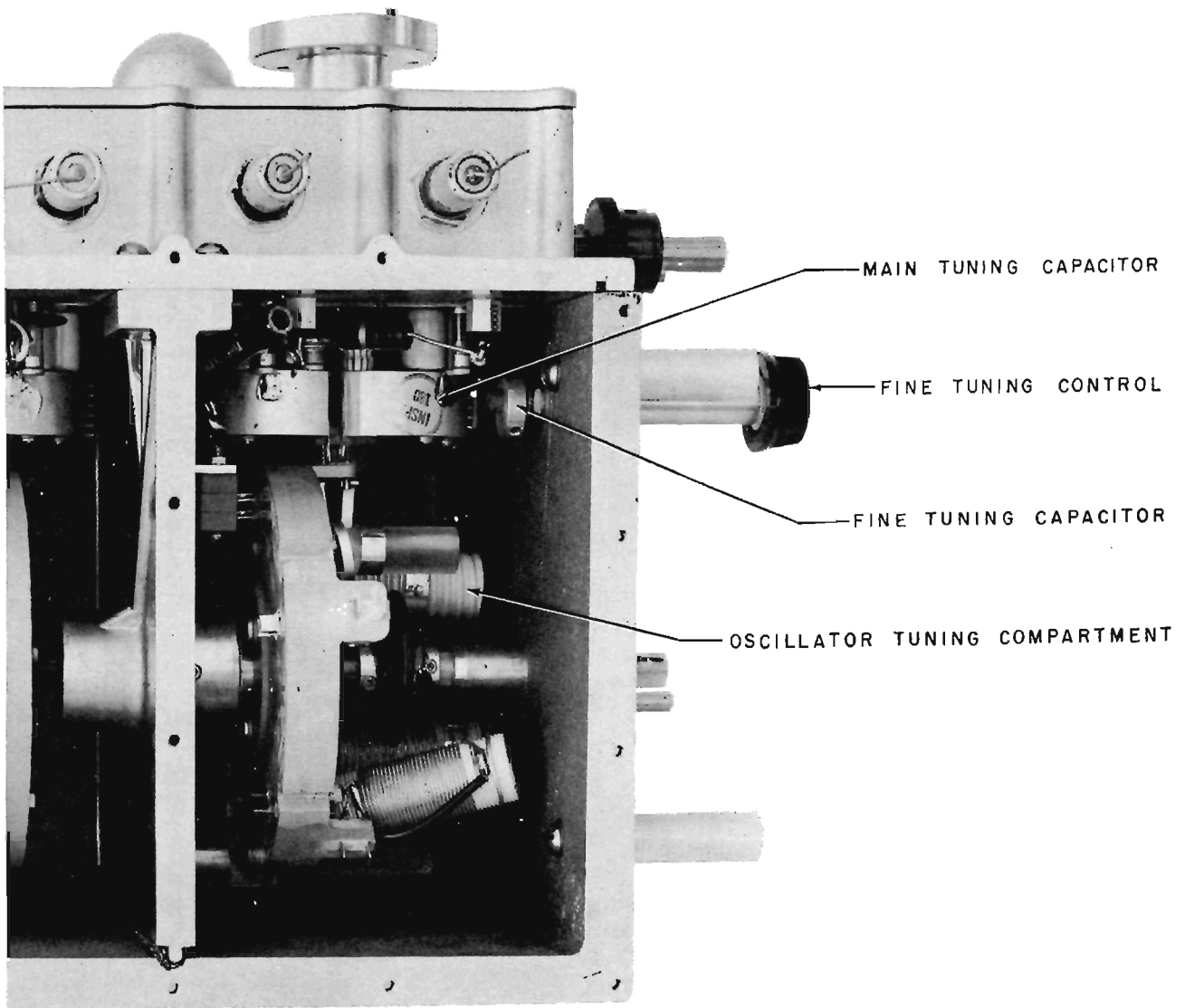

Figure 3-4. R-F Oscillator Compartment showing Fine Frequency Tuning Control.

the dot points to the left, the vernier capacity is maximum; when the dot points to the right the capacity is minimum. The accompanying figure shows the vernier device as it is mounted within the oscillator tuning compartment of the r-f generator assembly.

The circuit diagram for the oscillator is shown in Figure 3-3. The oscillator tube, V6, is operated across the -165 volt and +225 volt supplies with considerable series resistance to limit the maximum plate current that can flow. The plate is series-fed through a 3000-ohm resistor, R45, which also serves to isolate the tuned circuit from r-f ground at C15, while the cathode is returned to -165 volts

through R42 and R43. Cathode by-pass capacitor C25 is actually part of the tube mounting plate and is not visible when the plate is in position. R42 prevents resonance in the cathode lead; R43 in conjunction with R45 limits the maximum plate current that can flow through V6. Bias for the control grid is obtained across grid leak resistor R44, which under usual conditions develops approximately 70 volts of bias. C16 couples the tuning coil to the grid, the drive being determined by the ratio of grid-plate to grid-cathode impedance. These impedances consist partly of inter-electrode capacity, shown as dotted components in the partial schematic diagram, and largely of lumped constants in the tuned circuit. The grid-plate capacity is shunted by the tuned cir-

cuit and a small trimmer capacitor C18, while the grid-cathode capacity is shunted by trimmer capacitor C59. C18 sets the minimum capacity of the tuned circuit and is used to adjust the high-frequency limit of all bands when the oscillator tube is replaced. C59 is an additional adjustment usually set for minimum capacity and requiring no readjustment. This capacitor has minor effect on the grid drive at the high frequency ends of the bands and is usually set for maximum drive. The inductances of the tuned inductors is variable over a small range by adjusting a single shorted turn on each coil for the A, B, and C bands and by adjusting the size of the single loops for the D and E bands. These adjustments are used at the factory to set the low-frequency limit of each frequency band.

Heater voltage for the oscillator tube is obtained from a multivibrator operating on regulated voltage which supplies stable heater power. All power to the oscillator tube is brought through the housing by special filters having high attenuation of radio frequencies to prevent conduction of the r-f energy outside the instrument. The entire oscillator circuit is contained in the cast aluminum r-f generator assembly shown in Figure 3-2a. The tuned circuits are located in a lower front compartment, the other

circuits in a tube compartment above. An inside view of the r-f generator assembly is shown in Figure 3-2b. The oscillator tube is mounted through the top of the tuning compartment so that the grid and plate elements project through the top plate into the tuning compartment, while the heater and cathode elements remain above the top plate. Mounting facilities are contained in the upper compartment, and the tube may be replaced from the upper compartment without entering the tuning compartment.

3-4 RADIO FREQUENCY POWER AMPLIFIER

A loosely coupled secondary winding on each of the oscillator coils couples r-f energy from the oscillator to the radio frequency power amplifier, V8, which amplifies the energy for application to the output attenuator. The circuit consists of a 5876 "pencil" triode connected as a grounded-grid, cathode-modulated amplifier. The plate circuit of the amplifier is tuned in the same manner as the oscillator, with a similar split-stator capacitor and five untapped coils mounted on a revolving turret. The amplifier tuning capacitor is ganged with the oscillator capacitor by a double-ended worm drive. The amplifier capacitor is provided with a mechanical

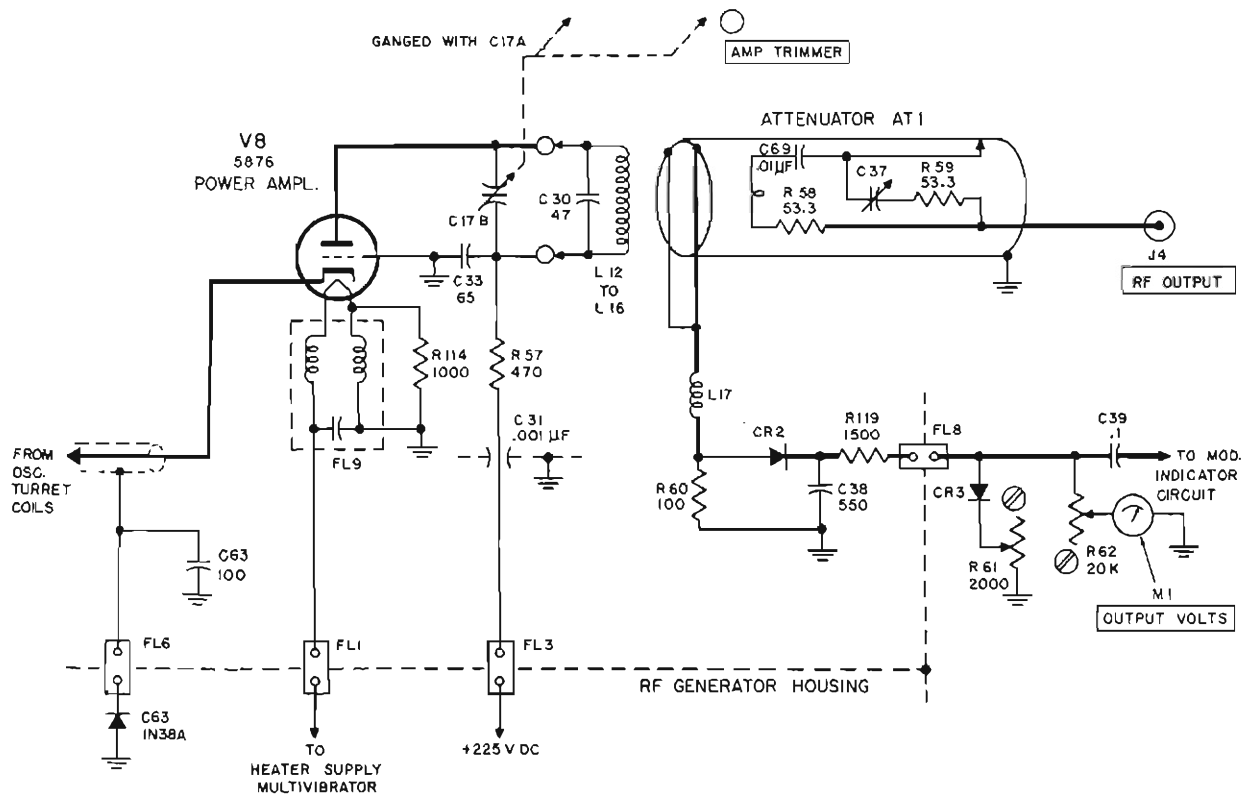

Figure 3-5. Schematic Diagram of Radio Frequency Power Amplifier

linkage, controlled from the front panel, to shift the rotor plates from their normal tracking position with respect to the oscillator. This control allows the amplifier tuning to be trimmed for maximum output at all frequencies.

The coil mounting turret is also ganged with that of the oscillator. Tuned coils are wound with copper wire on teflon forms, and the coil in use is so located to be inductively coupled to the output attenuator probe.

The circuit diagram for the r-f amplifier is shown in Figure 3-5. The power amplifier tube is operated across the -165 and +225 volt supplies. The plate is series-fed from the +225 volt supply through decoupling filter R57 and C33. The cathode is returned through resistors R35 and R36 to the -165 volt supply. R36 matches the higher impedance of the cathode circuit of V5 to the lower impedance of the cathode circuit of V8, while R35 is the cathode bias-developing resistor. R35 is also the cathode load resistor for control tube V5, and the bias voltage developed across R35 is largely controlled by the current established in V5. The modulating signal is also developed across R35 and with the bias voltage is fed through filter FL6 to the cathode of V8. Filter FL6 cuts off sharply at approximately 6 megacycles but allows the modulation signal to pass unattenuated to the cathode of V8. Crystal diode CR7, connected between the cathode return circuit and ground, limits the lowest potential to which the cathode can be driven to zero volts. This arrangement protects V8 from the effects of any negative switching transients which might be applied to its cathode. The plate circuit is tuned by C17B and coils L12 through L16. The inductances of the tuned coils can be adjusted over a small range by means of metal sleeves between the cores and coils on the B, C, and D bands and by altering the winding shape and size on the A and E bands. These adjustments are set at the factory to track the low frequency end of each band with the frequency of the oscillator.

Heater supply voltage for the r-f amplifier and oscillator is obtained from the regulated heater supply multivibrator. Filter FL9 in the heater circuit reduces incidental frequency modulation by preventing leakage of modulating signals between the heaters of the oscillator and amplifier tubes. The tuned circuits of the r-f amplifier are contained in the rear compartment of the r-f generator housing (see Figure 3-2b). The other amplifier circuits are located in the compartment above. The amplifier tube is mounted through the top of the tuning compartment so that the plate element projects through the top plate into the tuning compartment. The heater and cathode elements are in the upper compartment and the tube may be replaced without entering the tuning compartment.

3-5 OUTPUT ATTENUATOR AND R-F POWER MONITOR

To extract power from the r-f power amplifier, a piston attenuator is used. The housing for the attenuator projects through the rear of the r-f generator housing and terminates, open-ended, close to the r-f amplifier plate circuit inductor (see Figure 3-2b). Figure 3-6 shows the front view of the attenuator probe removed from the attenuator housing. The non-resonant, single-turn, pickup loop at the end of the attenuator probe couples energy to an impedance-matching network, C37, R58, and R59, mounted on the face of the probe and through a section of double-shielded coaxial cable to the RF OUTPUT jack. Capacitor C37 is actually a movable slug in the probe body. It allows minor adjustment of the internal impedance of the generator so that a minimum standing wave ratio is obtained when the output jack is terminated in a 50-ohm load.

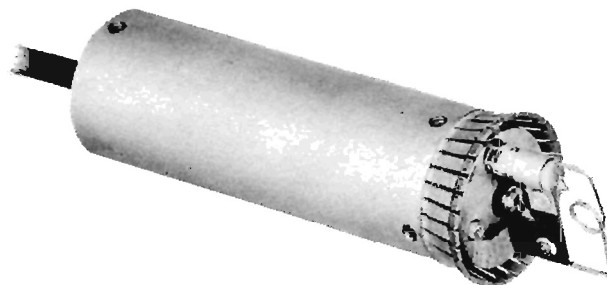

Figure 3-6. R-F Pickup Probe for Output Attenuator

The attenuator probe is positioned in its housing by a wire cable driven by a ball-bearing mounted pulley system coupled to a shaft from the front panel attenuator dial. Cable tension is adjustable and is carefully set for minimum back-lash. Friction throughout the system has been reduced to as low a value as possible.

The r-f power level which is fed to the attenuator is sampled and continuously monitored by an antenna (two parallel wires crossing the open end of the attenuator housing) connected to a small detector assembly mounted under the housing inside the r-f amplifier tuning compartment (see Figure 3-2). This power level is indicated in both volts and decibels, over a limited range, on the front panel power level meter. A calibration mark on the meter marked SET LEVEL establishes a correct amount of power

fed into the attenuator housing for direct reading of the output attenuator dial calibration.

Radio frequency energy is coupled from the power monitoring antenna to a detector through L17, a small coil used to adjust the frequency response of the detector circuit. Crystal diode CR2 with return resistor R60 rectifies the radio frequency energy and produces a d-c voltage equal to half the peak-to-peak r-f voltage. C38 and filter FL8 remove the remaining r-f component and couple the d-c voltage to a compensating network, CR3 and R61. FL8 is specially designed to attenuate all radio frequencies above approximately 2 megacycles and to pass all frequencies below that frequency with little or no attenuation. CR3 corrects for non-linearities in detector CR2 when the r-f signal level is low and detection takes place in the non-linear region of the diode. The degree of compensation is set by potentiometer R61 and is adjusted to obtain accurate down-scale readings on the front panel power level meter. M1 is calibrated to indicate the rms value of the r-f output signal. Potentiometer R62 adjusts the sensitivity of the meter and is set at the factory with accurate vhf power measuring equipment.

3-6 MODULATOR SECTION

The purpose of the modulator section is threefold: to generate 400- and 1000-cycle sine waves for internal modulation of the generator; to amplify all modulation signals for application to the r-f power amplifier; to control the power level obtained from the r-f amplifier for all types of operation by varying the bias on the r-f amplifier tube. The modulator consists of a resistance-tuned oscillator, V2, shown in Figure 3-7, a limiter and single-stage video amplifier, V1 and V3, shown in Figure 3-8; and a cathode follower output stage and output level control tube, V4 and V5, shown in Figure 3-9. The modulator circuits are located along the upper portion of the right side chassis; the oscillator on the bottom portion.

The modulation oscillator is a resistance-tuned sine wave generator of the Wein Bridge type. Basically, the circuit consists of a two-stage resistance-coupled amplifier which is caused to oscillate by the use of a frequency-selective positive feedback circuit. At the resonant frequency there is no phase shift in the

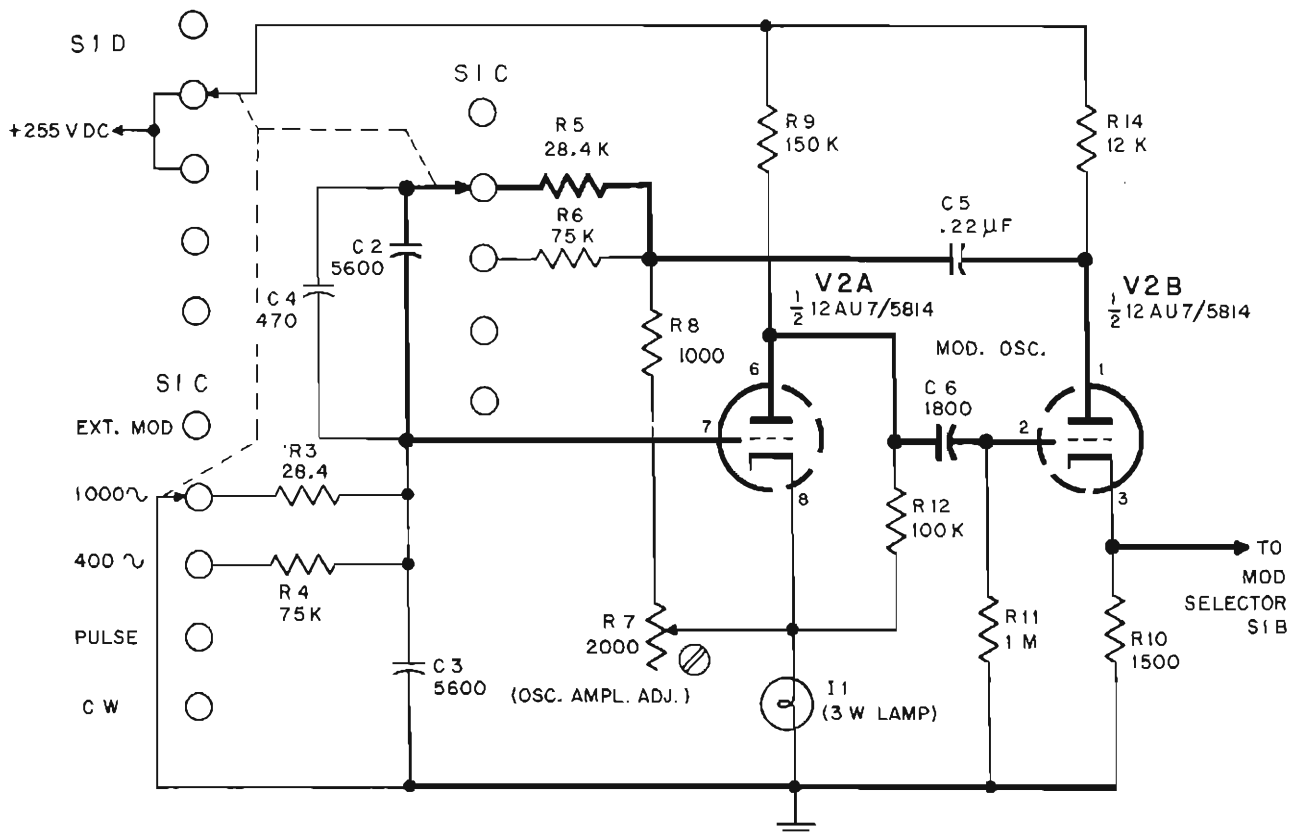

Figure 3-7. Schematic Diagram of Internal Modulation Oscillator

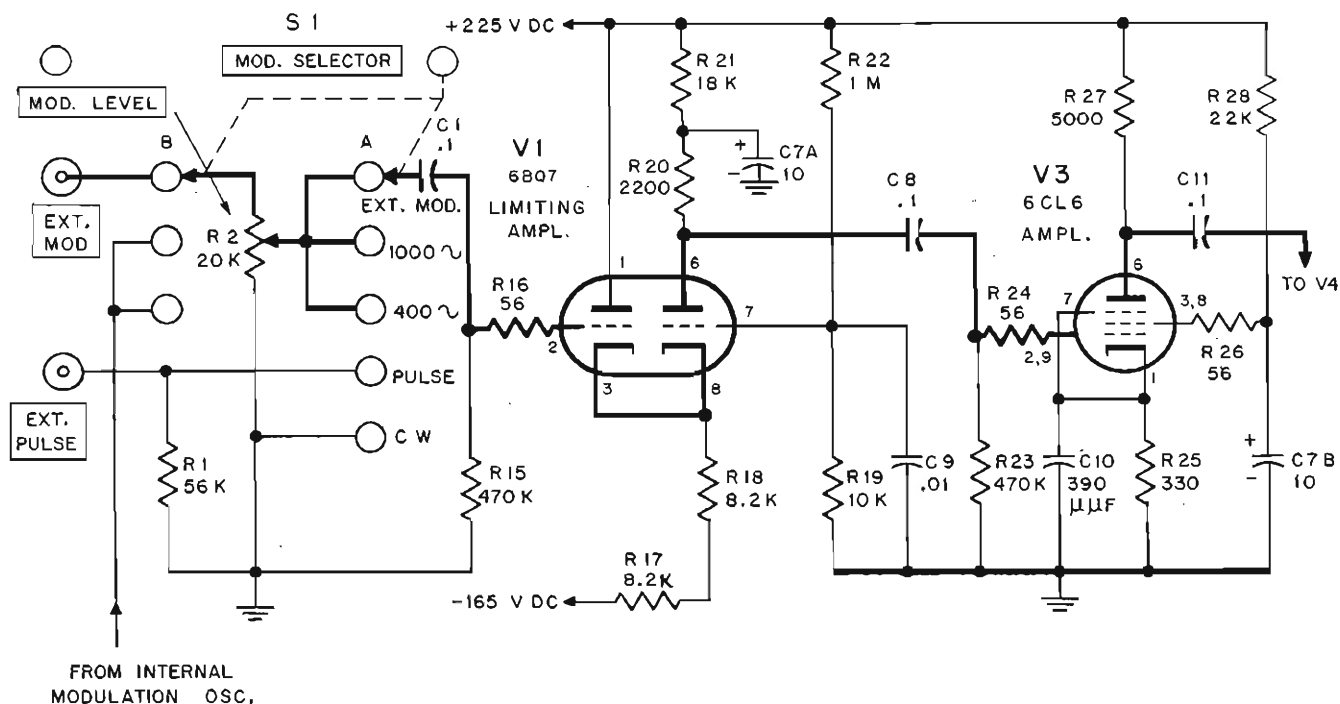

Figure 3-8. Schematic Diagram of Modulation Limiter and Amplifier

positive feedback circuit, so that a voltage of the resonant frequency on the grid of the first tube is reinforced by the output of the second tube and oscillation occurs. The two different frequencies of operation are obtained by switching two different sets of resistors, R3 - R5 and R4 - R6, into the positive feedback network when the MOD. SELECTOR is turned from 400 ν to 1000 ν . Precision resistors having good stability are used in the tuned circuit. Capacitors C2, C3, and C4 comprise the remainder of the tuned circuit. In addition, to the positive feedback network, a negative feedback circuit is also used to stabilize the oscillator, reduce distortion, and to maintain a constant output level. This circuit consists of a 3-watt lamp I1 (used as a thermal resistance element having a positive temperature coefficient), resistor R8, and amplitude adjusting potentiometer R7. The high positive temperature coefficient of the lamp provides automatic amplitude control of the signal, for if the amplitude of oscillation tends to increase, the current through the lamp tends to increase, thereby increasing the lamp's resistance. Consequently, the negative feedback tends to increase and amplitude of oscillation is maintained constant. The amplifier portion consists of two medium- μ triodes, V2A and B, in a conventional resistance-coupled circuit with the output voltage being obtained from the cathode

of the second stage. Although heater voltage is applied to the oscillator at all times the instrument is in operation, plate voltage is applied to V2 only when the MOD. SELECTOR switch is in the 400- or 1000-cycle position.

The sine wave signal from the modulation oscillator or from an external signal source is coupled through the MOD. LEVEL control to the limiter tube V1, a 6BQ7 twin triode, then to video amplifier V3, a type 6CL6 pentode. The purpose of V1 is to limit the peak amplitude of modulating pulses, since for pulse modulation the input signal is fed directly to the grid of the limiting amplifier without passing through the MOD. LEVEL control. The limiting action of V1 begins at approximately +2 volts peak which is considerably more than that required for 100% modulation of the output signal. Consequently, signals producing less than 100% modulation pass through the limiter unchanged. Limiting effectively squares the top of an incoming positive waveform above approximately 2 volts without affecting its rise and fall or introducing transients. The uninverted signal from amplitude limiter V1 is then amplified approximately 18 db by V3, a resistance-coupled 6CL6 pentode voltage amplifier, and coupled to output cathode follower V4.

From the limiter and amplifier, the modulating signal is fed to output cathode follower V4, a triode-connected type 6CL6 pentode. For sine wave modulation the signal from the cathode of V4 is coupled through switches S1E and S1F to the grid of the output level control tube V5 and superimposed on the variable bias voltage. The cathodes of both V5 and the r-f power amplifier V8 are connected together and returned to the -165-volt supply through resistor R35. Any signal placed on the grid of V5 is therefore directly coupled from the cathode of V5 to the cathode of the r-f power amplifier V8. The d-c voltage level established at the cathodes of the two tubes is determined largely by the current flowing in V5. The current in V5 is controlled by the dual potentiometer voltage divider, R34, R37, and R40, in the grid circuit. The cathode bias for V8, and consequently the r-f output power, is varied by front panel output level potentiometers R37A and R37B.

For pulse modulation the cathode of V4 is connected by the MOD.SELECTOR switch directly to the cathode of V5. The additional current drawn by V4 through common cathode resistor R35 produces a sufficiently high bias to cut off the r-f amplifier and reduce the r-f output to zero. The modulating pulses are not applied to the grid of V5, and it now serves only to control the peak level of the r-f out-

put pulse. Negative modulating pulses (the positive input pulse having been inverted in V3) at the grid of V4 cut off V4 and allow the cathode potential to return to the level set by V5 which establishes an r-f output level equal to the cw level as indicated on the output level meter. An r-f output pulse having an envelope shaped like the modulating pulse is then formed.

3-7 MODULATION-MEASURING CIRCUITS

The modulation-measuring circuits in the 608C indicate any modulation of the rf output signal between 0 and 100%. These circuits consist of a stabilized wideband amplifier and a bridge-type metering circuit. The measuring circuit reads the peak value of the rectified modulation signal and is accurate for all waveforms. The meter is calibrated to indicate the percent modulation of a given amount of rf carrier power. The amount is established by SET LEVEL on the output level meter and is accurate for all settings of the output attenuator.

The circuit diagram for the stabilized amplifier, shown in Figure 3-10, consists of two conventional resistance-coupled type 6AH6 pentodes, V18 and V19. The circuit is stabilized by negative feedback

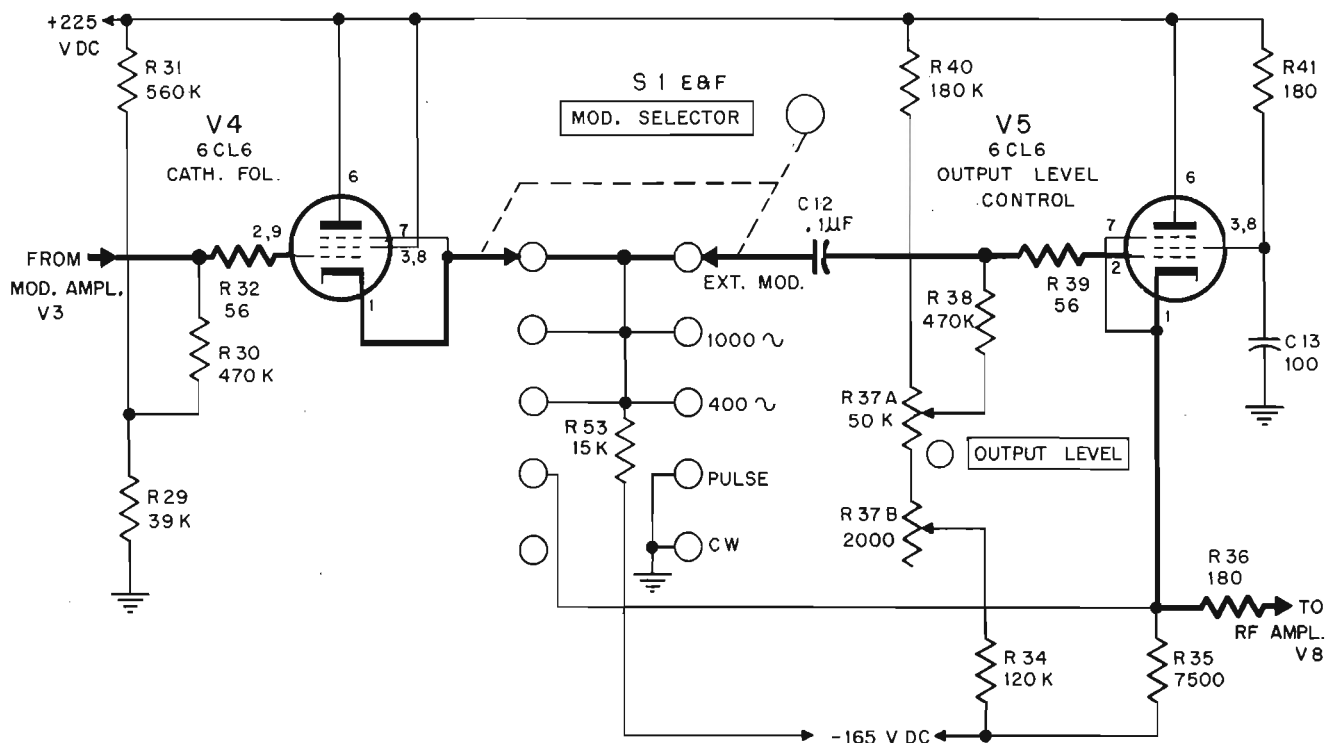

Figure 3-9. Schematic Diagram of Modulation Cathode Follower and Output Level Control Stages

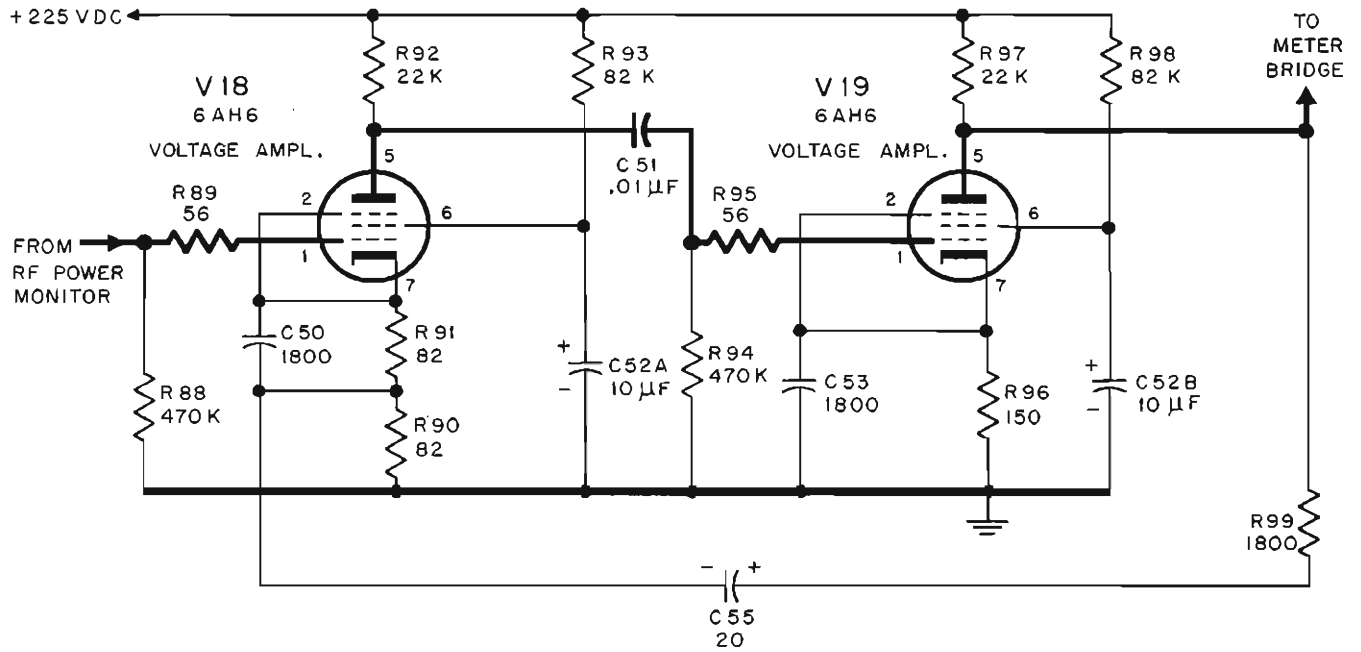

Figure 3-10. Schematic Diagram of Modulation Indicator Amplifier

and provides approximately 22 db gain to approximately 2 megacycles. The feedback loop covers both stages, the feedback signal being coupled from the plate of the second stage through dropping resistor R99 and blocking capacitor C55 to the cathode of the first stage. The circuit diagram for the bridge circuit is shown in Figure 3-11 and consists of diode rectifier V20 and twin-triode V21, the two triodes constituting two legs of the meter bridge. With no modulation signal applied to the amplifier, the steady-state d-c potential at the plate of amplifier V19 is coupled to the grids of both triodes V21. R101 limits the grid current that can be drawn by section A of V21. R105 acts as a cathode bias resistor in the B section to limit current flow in that section. With equal current flowing in the two sides of the bridge, the bridge is balanced and the meter reads zero. Potentiometer R106 is a front panel zero adjustment of the bridge that provides for variations in tube and component values.

A modulation signal from amplifier V19 is rectified by diode V20, and the peak value of the rectified voltage is applied to the triode in one leg of the bridge, unbalancing the bridge and causing the meter to read upscale. The triode in the other leg of the bridge is unaffected by the modulation signal as the signal is filtered out by the resistor

R101 and by-pass capacitor C58. Potentiometer R104 sets the sensitivity of the meter and is adjusted for correct calibration of the meter.

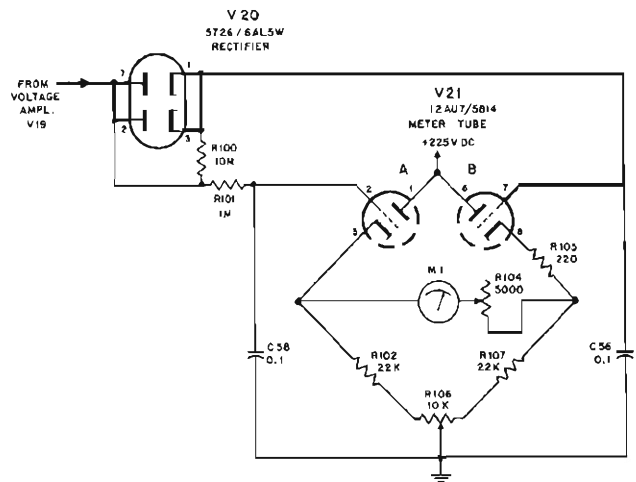

Figure 3-11. Schematic Diagram of Modulation Meter Bridge and Rectifier

3-8 POWER SUPPLY

The power supply for the signal generator consists of two electronically regulated high voltage supplies, one providing -165 volts dc, the other providing +225 volts dc, with the chassis at zero potential. Each regulator is supplied from a full-wave bridge-type silicon rectifiers with a separate high voltage winding on the power transformer. The power transformer also supplies a-c voltage for all electron tube heaters except the r-f oscillator and power amplifier. The primary winding of T1 is divided into two parts and may be operated in series for 230-volt lines or in parallel for 115-volt lines. The output of each regulated supply is adjustable by screwdriver adjusted potentiometers R80 and

R71 on the rear instrument chassis. The +225-volt supply uses the -165 supply for a reference voltage; consequently, a change in the -165 volts also affects the output from the +225-volt supply.

Since the two regulated power supplies are identical in operation, only the -165-volt supply will be discussed. Figure 3-12 shows the complete schematic for both supplies. V14, V15, and V16 constitute the voltage regulator circuit for the -165-volt supply. V15 is a constant-voltage tube which provides a reference bias for voltage amplifier V14. V16A operates as the regulator tube (or variable resistor) controlled by the voltage at the grid of V14. If the regulated output from the cathode of V16A tends to increase, the voltage at the grid of V14 tends to in-

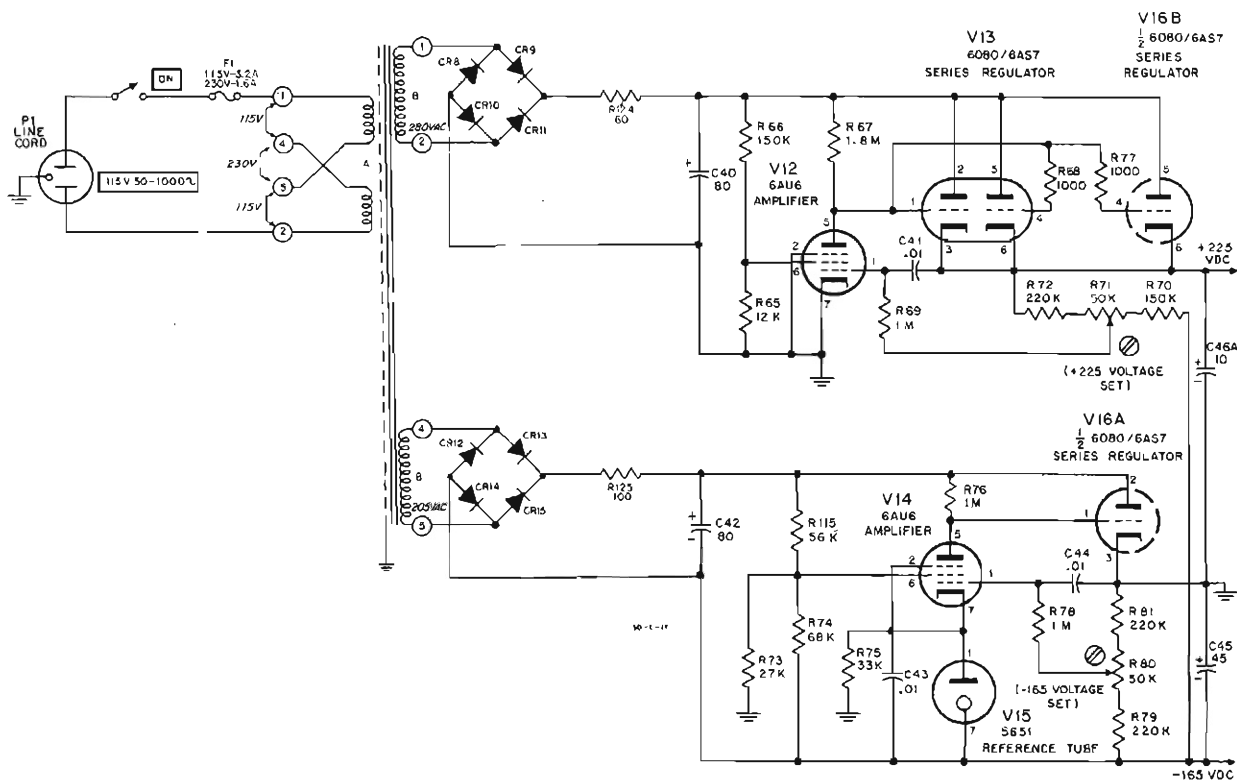

Figure 3-12. Schematic Diagram of Regulated Power Supplies

crease, causing V14 to draw more current. This lowers the plate voltage of V14 and consequently the grid voltage of V16A, resulting in a greater plate resistance for V16A. The greater plate resistance causes a greater voltage drop across V16A, instantaneously compensating for the increased voltage at its cathode and resulting in a substantially constant voltage output.

If the regulated output tends to decrease, the reverse of the above action occurs, also tending to maintain the cathode voltage constant. Ripple in the output voltage is coupled to the grid of V14 by capacitor C44, while slower variations in the d-c level are fed to the grid of V14 through voltage divider R79, R80, and R81. The bias of V14, and thus the output voltage level from V16A, is determined by the setting of R80.

The operation of the +225-volt supply is identical; but due to additional current requires (approximately 150ma), three regulator tubes (V13A and B, V16B) must be used in parallel. The reference voltage for the +225-volt supply is obtained directly from the output of the -165-volt supply.

3-9 HEATER SUPPLY MULTIVIBRATOR

To provide constant heater voltage to radio frequency tubes V6 and V8, a free-running multivibrator operating on the +225-volt regulated supply is utilized. The multivibrator develops square waves that are substantially constant in amplitude because the plate voltage excursion is limited in the positive direction by the +225-volt supply and in the negative direction by the maximum conductivity of the tube. The type 7119 has sufficient conductivity to cause the plate voltage to fall to approximately +25 volts during the negative half cycle. The multivibrator, which operates without bias, is grid-plate coupled and produces symmetrical waves. Transformer T2 couples the output of the multivibrator to heater circuits within the r-f generator housing. Potentiometer R87 is used to adjust the plate voltage of V17 and thereby acts to control the applied filament

voltage for V6 and V8. Resistors R84 and R85, in the grid circuit of the two triodes, prevent grid loading of the opposite plate circuits while the grid is in the positive part of its cycle. R83 and R86 are the grid return resistors. The schematic diagram for the heater supply multivibrator is shown in Figure 3-13.

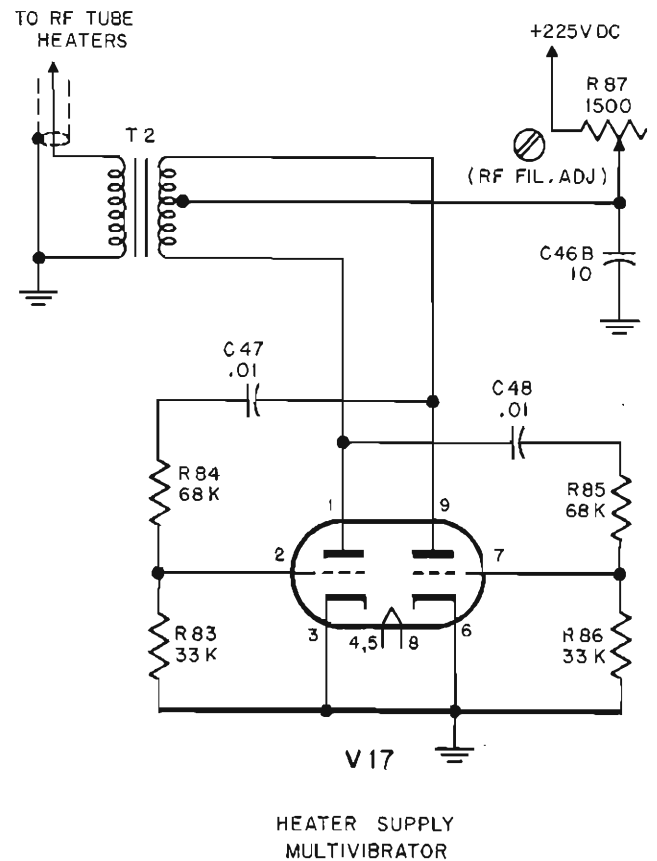

Figure 3-13. Schematic Diagram of Heater Supply Multivibrator

SECTION IV MAINTENANCE

4-1 INTRODUCTION

Section IV contains instructions for preventive maintenance, trouble localization, tube replacement procedures, and internal adjustments in the Model 608C Signal Generator. To assist with servicing the signal generator, a trouble shooting chart and circuit-tracing block diagram are also included. At the end of this section will be found additional locating illustrations, tube socket voltage and resistance diagrams, and the schematic diagram for the complete equipment.

The following information can be found in this section:

- 4-2 Cabinet Removal
- 4-3 Periodic Checks and Routine Care
- 4-4 Test Equipment and Special Tools Required
- 4-5 Localizing Trouble
- 4-6 Replacement of Electron Tubes
- 4-7 Radio Frequency Oscillator Tube Replacement
- 4-8 Radio Frequency Amplifier Tube Replacement
- 4-9 Replacement of Electron Tubes within the Regulated Power Supplies
- 4-10 Attenuator Probe Replacement
- 4-11 Replacement of Lamp I1
- 4-12 Calibration of the Percent Modulation Meter
- 4-13 Output Volts Meter Calibration and RF Power Monitor Service
- 4-14 Trouble Shooting Chart

4-2 CABINET REMOVAL

To remove the instrument chassis from the cabinet, loosen the four captive screws on the rear of the cabinet and pull the instrument from its cabinet by the guard-rail handles. The rear of the instrument chassis is supported on steel rollers and should move freely from the cabinet.

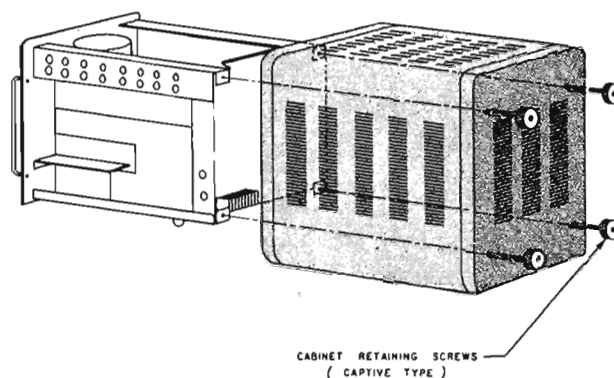

Figure 4-1. Cabinet Removal Diagram

4-3 PERIODIC CHECKS AND ROUTINE CARE

PREVENTIVE MAINTENANCE

Reasonable care in transporting, handling, and operating the 608C Signal Generator will help to prolong its useful life and minimize trouble. No special checks are required other than a general alertness for the effects of misuse, loose controls, condition of cables and connectors, and possible damage that may be evident in its general appearance. A limited but useful operational check may be performed without the use of external equipment by operating the equipment as instructed in paragraph 2-6, indications of normal operation being read from the two front panel meters. If the equipment has been subjected to unusual conditions - excessive moisture, dust, heat, vibration, etc. - it is suggested that the instrument be removed from the cabinet and inspected for dirt or moisture accumulation, loosened components, or any possible sign of damage. Forced air under medium pressure is recommended for dusting and drying, although care must be taken not to vary the settings of the internal adjustment potentiometers and capacitors during the process. When tightening nuts and screws,

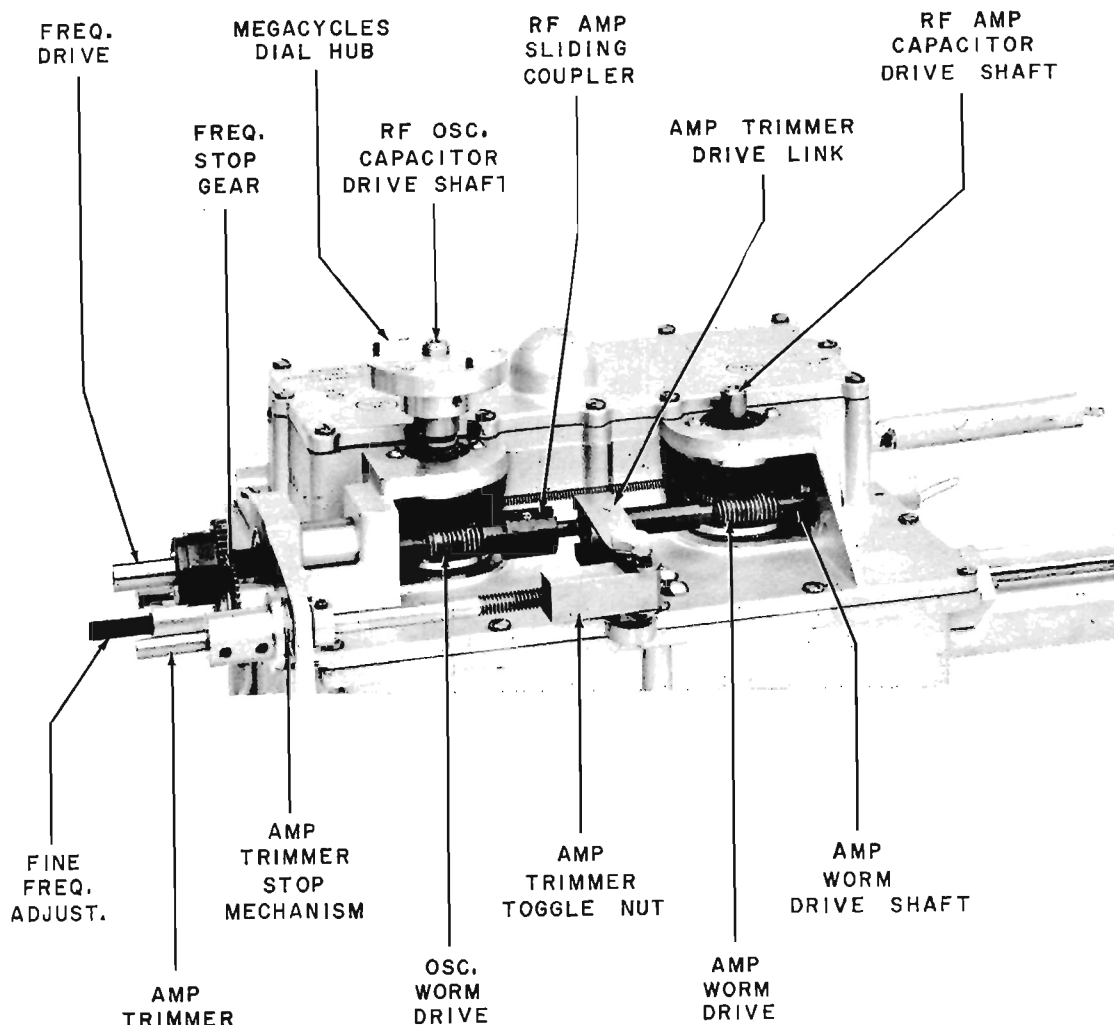

Figure 4-2. R-F Tuner Drive Mechanism

various degrees of pressure are required depending on the strength of the material and weight which is supported. Avoid overtightening.

LUBRICATION -

The 608C is thoroughly lubricated at the factory. The gears in the r-f generator housing operate at slow speeds and transmit negligible power. Fully shielded ball bearings are used in many applications and require no subsequent attention. Ball bearings that are not fully shielded require only light machine oil. The two worm gears used in the tuning capacitor drive should be cleaned and lubricated approximately every sixty days. If cleaning and relubrication are

needed after prolonged use of the instrument, excessive dust accumulation, or drying of lubricant, reference to the following chart and Figures 4-2 and 4-5 will assist with renewing the lubricants at various points on the r-f generator assembly. The two worm gears used in the tuning capacitor drive are lubricated with "Moly Lubricant". All remaining sleeve bearings and rubbing surfaces - including the small pulleys used in the attenuator drive system - are lubricated with a light synthetic oil such as Shell Tonna Oil G. The bakelite RANGE SELECTOR drive shaft and the attenuator drive shaft - not shown in the illustration - require Lubriplate grease #2 where they enter the r-f generator housing. In all cases, avoid over-lubrication.

LUBRICATION CHART

Lubrication Point (see Figures 4-2 & 4-5)	Lubricant
Oscillator and amplifier worm gears	"Moly Lubricant"
AMP. TRIMMER stop mechanism	Light machine oil, such as Shell Tonna Oil G
AMP. TRIMMER toggle nut	Same as above
AMP. TRIMMER drive link	Same as above
Amp. worm drive shaft	Same as above
Amp. sliding coupler	Same as above
Attenuator pulleys	Same as above
Attenuator drive shaft front panel bearing	Same as above
Attenuator housing guide slot	Lubriplate #2

4.4 TEST EQUIPMENT AND SPECIAL TOOLS REQUIRED

A special wrench for removing r-f power amplifier tube V8 is included with the signal generator

and is located inside the instrument cabinet mounted beside the r-f generator housing. Test equipment recommended for servicing the signal generator is listed in Table 4-1.

Table 4-1. Test Equipment Required for Maintenance

Name	Model No.	Application
Non-electronic multimeter	Simpson 260	General voltage, current and resistance measurements
Electronic multimeter (ac)	Ⓜ 400D/H/L or 403A	High impedance and/or low level a-c voltage measurements
Electronic multimeter (ac & dc)	Ⓜ 410B or 412A	High impedance ac or dc and VHF ac measurements
Oscilloscope	Ⓜ 130 or Ⓜ 150A	Waveform measurements
Detector mount	Ⓜ 420A	- - -
Test oscillator	Ⓜ 200CD	External modulation of signal generator
Pulse generator	Ⓜ 212A	External pulse modulation of signal generator
Frequency Meter Wavemeter Accuracy = 0.1% min.	- - -	Main frequency dial calibration
Power Meter	Ⓜ 430 C	VHF output power measurements
Bolometer mount	Ⓜ 476A	- - -

4-5 LOCALIZING TROUBLE

The first step in correcting any trouble which may occur in the signal generator is to isolate the section of the equipment that causes the trouble. The various circuits of the 608C Signal Generator occupy easily defined areas and offer very good circuit accessibility. The locations of the various sections are shown in Figures 4-7, 4-8, and 4-9. Figures 4-10 and 4-11 will also prove helpful in locating circuits within the r-f generator housing.

Trouble ordinarily occurs in only one section of an equipment at one time; therefore, it is usually necessary to correct only the one trouble. Isolation of a circuit failure is best accomplished by considering the basic sections shown in the block diagrams in Figures 2-2 and 3-1. Careful determination of the nature of a trouble symptom usually leads to the section at fault. To aid in servicing, a trouble shooting chart that indicates certain possible specific troubles and their symptoms and a signal tracing block diagram are included. In addition, tube socket voltage and resistance diagrams and the schematic diagram for the complete equipment are included at the end of this section.

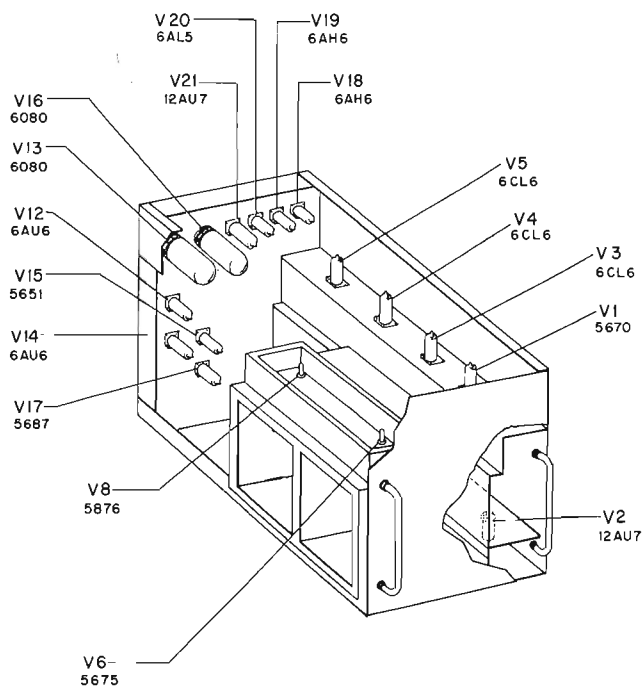

Figure 4-3. Diagram showing location of Tubes in Model 608C

4-6 REPLACEMENT OF ELECTRON TUBES

When replacing tubes in the Model 608C, it is recommended that a check be made on the operation of the instrument before and after each new tube trial; and if no improvement is noticed, the original tube should be returned to the socket. Figure 4-3 locates all electron tubes in the equipment. Table 4-2 lists the tubes of the signal generator with a suggested check and paragraph reference if adjustments are necessary.

This instrument may have type 6AS7G tubes, replacing type 6080 tubes.

These tubes are electrically interchangeable, and replacement tubes can be of either type. The type 6AS7G tubes have special clamp adapters around the base, and these adapters should be placed on

Table 4-2. Adjustments and Checks Required after Tube Replacement

Tube Positions	Check or Paragraph Reference
V1	Check operation with modulation
V2	Check operation with internal modulation
V3	Check operation with internal modulation
V4	Check operation with internal modulation
V5	Check range of output level control (should obtain 0 to full-scale deflection on OUTPUT VOLTS meter)
V6	See paragraph 4-7
V8	See paragraph 4-8
V12-17	See paragraph 4-9
V18	Check for indication of modulation percentage
V19	Check for indication of modulation percentage
V20	Check for indication of modulation percentage
V21	Check zero set of PERCENT MODULATION meter

replacement tubes of the 6AS7G type. They may be discarded, however, if type 6080 tubes are used for replacement.

4-7 RADIO FREQUENCY OSCILLATOR TUBE REPLACEMENT

Replacement of the radio frequency oscillator tube V6 may affect the calibration of the frequency dial and may change the heater supply voltage for the oscillator and power amplifier tubes. In addition, the plate current of new type 5675 pencil triode tubes may differ widely in a given application. The heater voltage must be checked and, if necessary, reset to proper value; plate current must be held to between 18 and 27 milliamperes by tube selection. To replace oscillator tube V6, refer to Figure 4-4 and proceed as follows:

- a. Remove frequency dial and top plate from r-f generator housing to gain access to tube compartment. The frequency dial is accurately indexed on its hub by two pins which assure exact positioning upon replacement of dial on hub.
- b. Remove socket from base of V6 by straight pull.
- c. Remove cathode clip from tube.
- d. Remove the two 6-32 screws holding retainer plate; then remove plate and fiber spacer.
- e. Lift tube gently from hole by straight pull.
- f. Replace tube in reverse order of above steps.
- g. Using an average-responding, a-c electronic voltmeter calibrated in rms volts, such as the $\text{\textcircled{P}}$ Model 400D or 400H, measure the voltage at FL1. If necessary, adjust R87 to obtain a reading of 7.1 volts between the inside terminal of FL1 and ground. Allow to run for 4 hours.
- h. With equipment turned off, break green lead to C15, a feed-thru type capacitor in the r-f generator tube compartment, and insert a 0-50 ma milliammeter.
- i. Set the frequency range switch to the E band and turn equipment on. Milliammeter should read between 18 and 27 ma. If it does not, try another replacement tube.

- j. Using an external standard calibrator of known accuracy, check the frequency calibration throughout the range of the signal generator, noting points that are significantly off frequency.

- k. To correct the frequency calibration at the high frequency end of all bands simultaneously, adjust trimmer capacitor C18, which is accessible in the tube compartment in r-f generator housing. This adjustment has only minor effect at the low frequency ends of the ranges.

4-8 RADIO FREQUENCY AMPLIFIER TUBE REPLACEMENT

Replacement of the r-f amplifier tube can affect the heater voltage applied to r-f oscillator and power amplifier tubes in the generator housing and may also limit the maximum power output available from the signal generator. Both of these possibilities should be checked as described below. To remove r-f amplifier tube V8, refer to Figure 4-4 and proceed as follows:

- a. Remove frequency dial and top plate from r-f generator housing to gain access to tube compartment.
- b. Remove socket from base of V8 by straight pull.
- c. Remove cathode clip from tube.
- d. Using the special wrench located on instrument chassis convenient to generator housing, loosen threaded retainer ring which holds V8 in housing. Remove retainer ring and neoprene washer.
- e. Withdraw old tube and replace with new type 5876 tube
- f. Following replacement of V8, check and, if necessary, adjust the heater voltage as instructed in paragraph 4-7g for the r-f oscillator tube.
- g. Check the power output throughout the full frequency range of the signal generator reading the self-contained power level meter with the AMP. TRIMMER control set for maximum output. A full-scale reading should be obtainable over the entire frequency range.

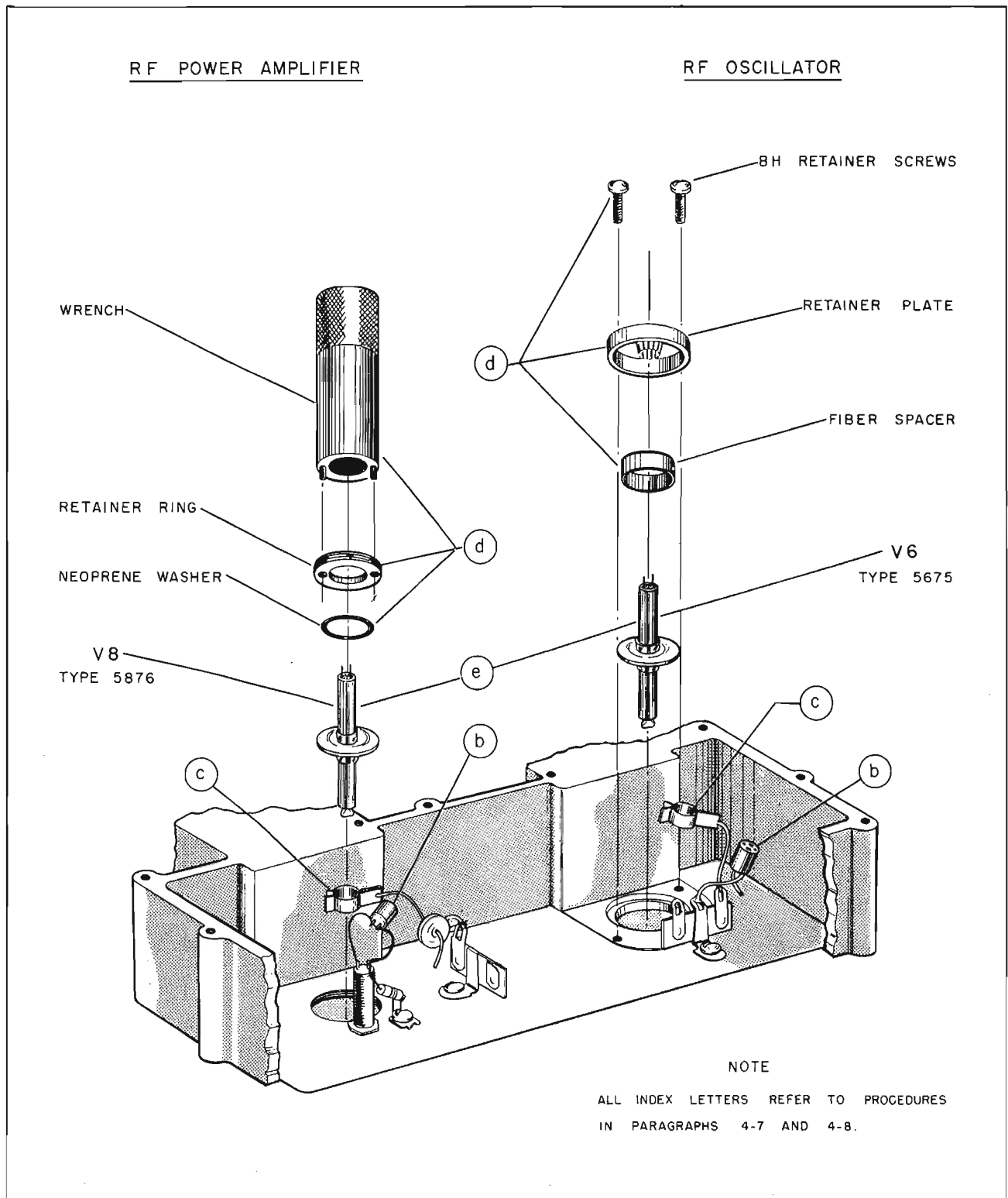

Figure 4-4. Diagram showing Tube Replacement for R-F Oscillator and Amplifier

4-9 REPLACEMENT OF ELECTRON TUBES WITHIN THE REGULATED POWER SUPPLIES

The output voltage from either or both of the regulated power supplies may be affected slightly by a change in any one of the tubes within the supplies. The two power supplies are interdependent in that the setting of the +225-volt supply depends upon a reference point established by the -165-volt supply; therefore, a tube change in the -165-volt supply can also change the output from the +225-volt supply. All tubes and components in the power supplies are located on the chassis at the rear of the signal generator.

To check the output voltage from the power supplies following service or tube replacement, refer to Figure 4-8 and proceed as follows:

- a. With the MOD.SELECTOR switch set to the 1000 position and the other controls in any position, turn equipment on.
- b. Connect the positive lead of a voltmeter having a sensitivity of 5000 ohms per volt or better to ground.
- c. Connect the negative lead to pin 7 of V15.
- d. Voltage should now read -165 volts. If necessary, adjust R80 to obtain -165 volts. This voltage should then remain stable with line voltage changes between 103 and 127 volts.
- e. Reconnect voltmeter with the negative lead to ground and the positive lead to pin 6 of V13.
- f. Voltage reading should be +225 volts. If necessary, adjust R71 to obtain +225 volts. This voltage must remain substantially constant with line voltage changes between 103 and 127 volts.
- g. Using an average responding, electronic a-c voltmeter calibrated in rms volts, such as the $\text{\textcircled{D}}$ Model 400D, measure the voltage between FL1 and ground. The voltage at this point is the filament voltage for the r-f oscillator and power amplifier tubes V6 and V8 and is furnished by V17, operating as a multivibrator.
- h. Adjust R87 for 7.4 volts as read on the 400D scale. FL1 has approximately 0.3 volt IR drop, hence, the voltage on the tubes will read 7.1 volts.

4-10 ATTENUATOR PROBE REPLACEMENT

If the electrical components of the output attenuator are damaged, such as described in the "WARNING" on page II-3 (paragraph 2-5), repair or replace if necessary. This condition may be confirmed by measuring the vswr of the attenuator at the RF OUTPUT jack. The vswr should measure less than 1.2. If investigation shows an attenuator to be defective, proceed as follows:

CAUTION: During removal and replacement of the probe, extreme care must be exercised. The probe consists of a cylindrical metal tube with a series of spring contact fingers around its periphery at one end, which can be accidentally bent or twisted. Also, it will be noted that one of the fingers is bent toward the center of the probe slightly. Do not attempt to straighten it since it has been made this way to assure clearance between the probe and the end of the guide slot in the attenuator housing. It is of greatest importance to make certain that the probe is not subjected to shock. If the probe is subjected to shock, the electrical components attached to the end of the probe can be broken or their position altered with a consequent change in the electrical characteristics of the probe.

- a. Turn the attenuator control on the front panel until the probe reaches the end of its travel to the rear of the attenuator housing.
- b. Refer to Figure 4-6b. Remove the nut and washer that hold the drive cable in the probe drive screw in the top of the attenuator probe. Lift the cable out of the screw slot.
- c. Remove probe drive screw from probe body by removing inner nut and unscrewing.
- d. Carefully remove the probe by sliding it out of the attenuator housing.
- e. If the damage to the attenuator probe is limited to a burned out resistor and if a replacement resistor is available, the attenuator may be repaired by carefully unsoldering the old resistor, using a low temperature soldering iron, and replacing the resistor. Soldering must be done quickly and neatly with low temperature solder. Care must be taken to duplicate the original workmanship as closely as possible by positioning the new part exactly as the old one was and by applying as little heat in the soldering process as is possible. Capacitor C37 need not be adjusted unless it has been damaged. This capacitor consists of a metal pin with a thin plastic coating within a sleeve. The sleeve is retained by a #4 Allen screw in the side of the probe

body. If the coating on the pin is pierced, the pin must be replaced. Again it is important to retain the original positioning. Loosening the set screw in Figure 4-6 allows for adjustment or replacement of the pin and sleeve.

f. If repair is not possible, the probe and cable must be replaced. It will then be necessary to remove the RF OUTPUT jack from the front panel and release the cable from the clamp holding the cable to the top of the side gusset. The entire probe assembly may then be removed from the instrument. Replacement probes are complete with cable and panel jack and require no adjustment of the impedance-matching network upon installation.

g. Insert the new or repaired probe in the attenuator housing. Care must be taken in starting

the probe into the housing since the diameter at the probe contact fingers is slightly greater than the inner diameter of the housing. The contact fingers should be depressed slightly while starting the probe into its housing.

CAUTION: Under no circumstances should the probe be forced.

h. Replace the split drive screw in the probe, making certain that the screw slot is parallel to the axis of the housing.

i. Set the attenuator drive cable in the screw slot and replace both washers and nut. Do not tighten the nut. The cable must move freely through the slot until the probe penetration has been set.

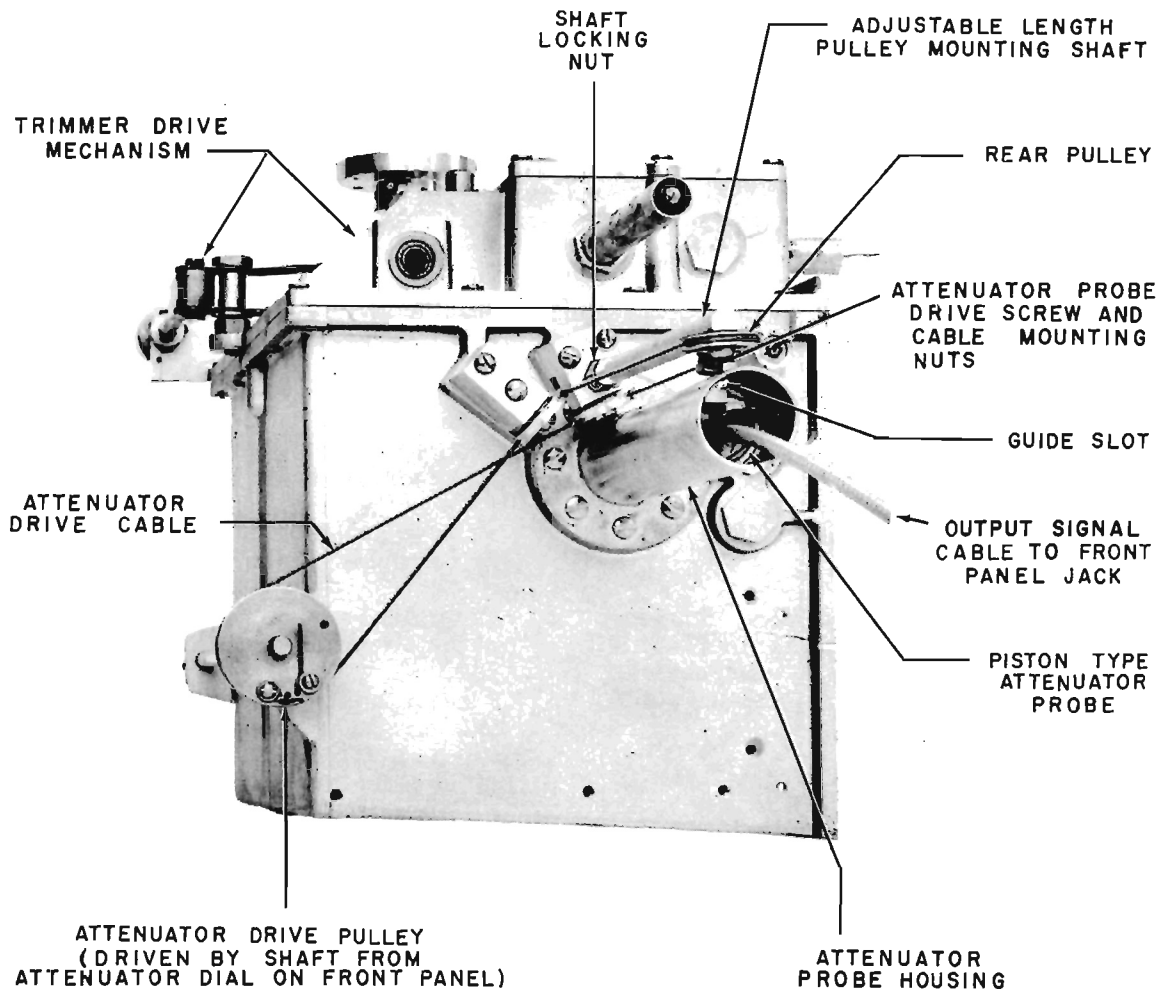

Figure 4-5. R-F Generator Assembly Rear View, showing Output Attenuator Drive System

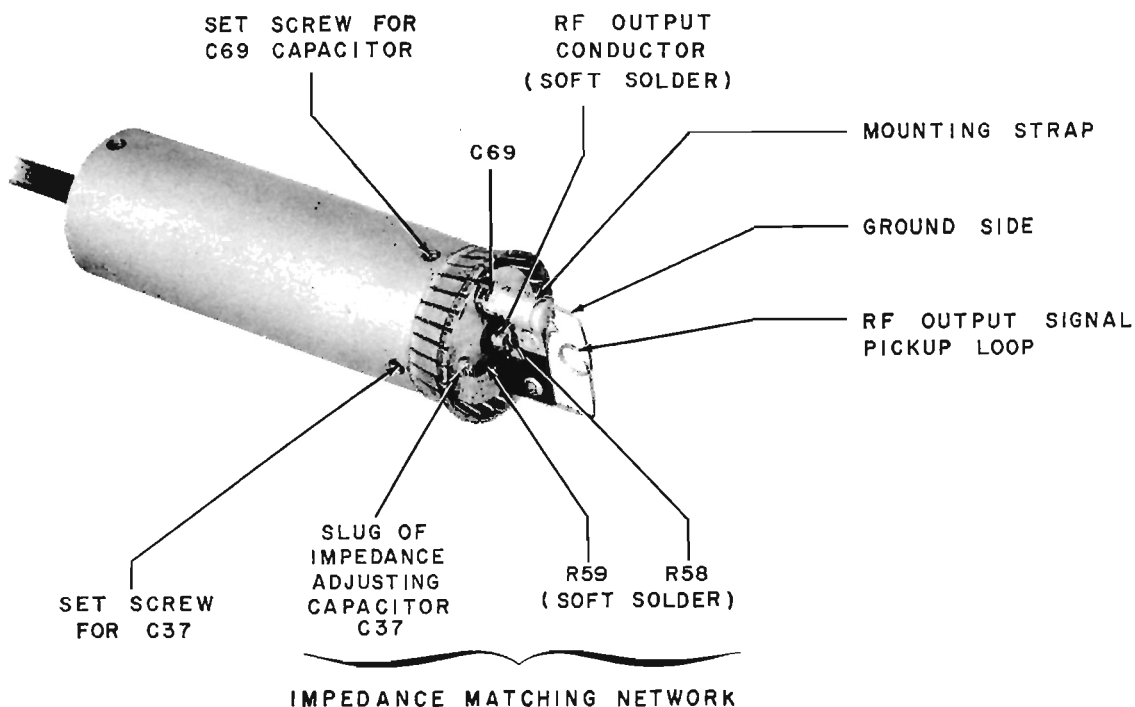

Figure 4-6a. R-F Output Attenuator Probe, showing Front View of Pickup Loop

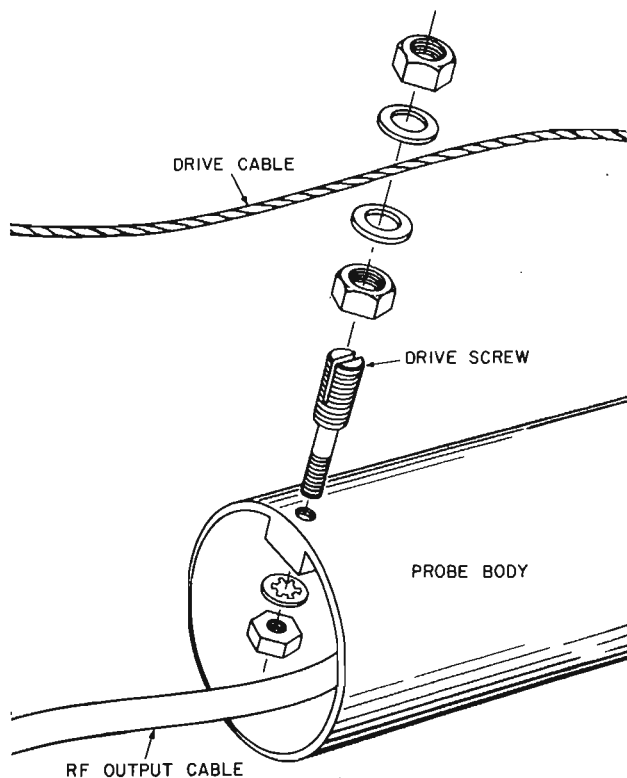

Figure 4-6b. Rear View Showing Attaching Parts

j. Secure the r-f cable to the clamp on the side gusset. (Cable routing is shown in Figure 4-8 and 4-9.)

k. Connect the instrument to a source of 115-volt a-c power. Turn on the power switch.

l. Unless otherwise specified, the operating controls should be set as follows:

- | | | |
|-------------------|---|------------------------|
| MOD. SELECTOR | - | CW |
| FREQUENCY CONTROL | - | 20 megacycles |
| FREQUENCY RANGE | - | A band |
| AMP. TRIMMER | - | Adjust for max. output |
| OUTPUT LEVEL | - | Adjust for SET LEVEL |
| MOD. LEVEL | - | Counterclockwise |
| Attenuator | - | 0 dbm |

m. Connect a power meter, such as the $\text{\textcircled{P}}$ Model 430B, through a bolometer mount ($\text{\textcircled{P}}$ Model 476A or equivalent) to the RF OUTPUT jack.

n. Remove r-f generator side plate so that clearance between the attenuator probe and r-f amplifier tank may be observed.

CAUTION: The following step must be executed as carefully as possible to insure that the pick-up loop does not make contact with any one of the amplifier coils. These coils are the power amplifier tuning coils and are at B+ potential. Contact with the attenuator pick-up loop could be destructive to the attenuator components.

o. With the attenuator dial set exactly on 0 dbm and the OUTPUT VOLTS meter set to SET LEVEL, manually advance the attenuator probe into the housing until the r-f output signal is exactly 1 milliwatt (0 dbm) as read on the external power meter.

p. Tighten down the nut on the split screw so that the probe may be actuated by its drive system. Carefully check to see that there is clearance between the various turret coils and the pick-up loop when the attenuator dial is set to +7 db.

q. Replace r-f generator side plate. Using the power meter, check the output at 0 db (1.0 milliwatt) at the higher frequencies on the B, C, D, and E bands. If necessary, the self-contained output meter calibration can be adjusted by means of R62 (see Figure 4-9). See paragraph 4-13 for complete OUTPUT VOLTS meter recalibration instructions.

4-11 REPLACEMENT OF LAMP I1

Lamp I1 acts as a thermal resistance having a high positive temperature coefficient and is used to maintain constant output voltage from the 400- and 1000-cycle oscillator. The S6 type lamps used for this purpose ordinarily vary widely from one lamp to another and produce widely varying output voltage from this oscillator. Potentiometer R7 is provided for adjustment of the oscillator output voltage for various S6 lamps.

After the lamp I1 has been replaced, the oscillator voltage, as measured at pin 3 of V2, should be adjusted to 2 volt rms; if it cannot be adjusted to this value, another lamp must be tried.

4-12 CALIBRATION OF THE PERCENT MODULATION METER

Recalibration of the PERCENT MODULATION meter may be necessary following a repair of the modulation measuring circuits or after replacement of the meter itself. The method of calibration outlined below requires the use of a peak-reading electronic voltmeter capable of measuring a-c voltages to 500 megacycles, such as the Φ Model 410B, and re-

quires a tuned step-up transformer to obtain adequate output voltage from the generator for measurement. Basically, this method of modulation measurement consists of measuring the peak value of the r-f output signal with and without modulation. A doubling of the peak output voltage indicated on the multimeter represents 100% modulation of the output signal, while lesser percentages of modulation are indicated by proportionally smaller voltage increments.

To measure modulation by the voltmeter method, it will be necessary to fabricate a tuned circuit similar to that shown below. Materials at hand may be used as substitutes for those listed.

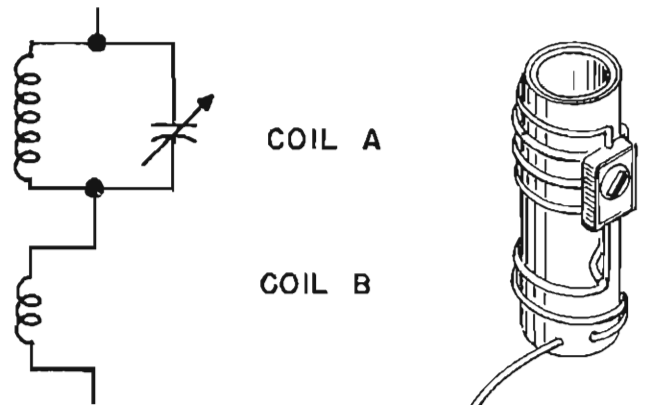

Coil form --
3/4 inch diameter by approximately 2 inch long.
Ceramic, polystyrene or similar material.

Coil A --
5 turns of solid #20 wire spaced 1/8 inch between turns.

Coil B --
2 turns of solid #20 wire spaced 1/8 inch between turns. (Approximately 1/4 inch spacing between coils A and B.)

Tuning capacitor --
7 to 45 μ f.

The following procedure for calibrating the PERCENT MODULATION meter may be used with either internal or external modulation.

a. With the controls set as below, turn the power switch on and allow the instrument to warm up.

FREQUENCY RANGE - C band
 MEGACYCLES dial - 75 to 85 mc
 MOD. SELECTOR - 1000
 AMP. TRIMMER - Adjust for max. output
 OUTPUT VOLTS meter - Adjust to SET LEVEL
 PERCENT MODULATION - Adjust for 0%
 Attenuator - 0 dbm

- b. Connect the signal generator to the test apparatus as shown in the diagram below.

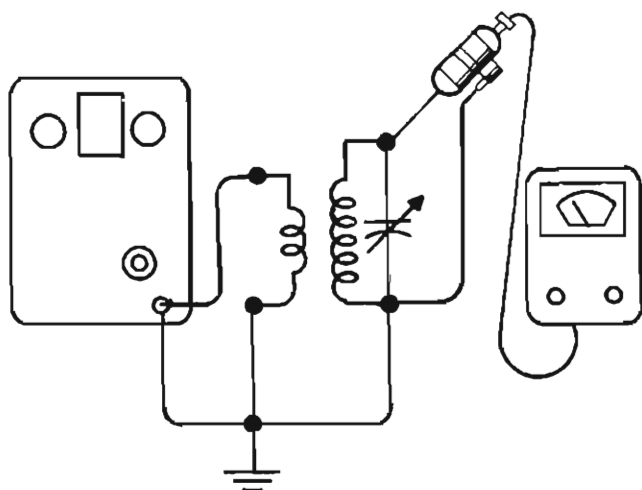

Ⓜ Model 608C Ⓜ Model 410B
 VHF Signal Generator VHF Vacuum Tube Voltmeter

- c. Set the 410B voltage range switch to the 10-volt a-c range.
 d. Adjust the capacitor on the r-f transformer to obtain maximum output as read on the vacuum tube voltmeter.
 e. Reading from the 0- to 3- volt scale on the 410B, adjust the output attenuator on the 608C for a reading of 1 volt on the 410B.

NOTE: The actual voltage from the tuned circuit will be within the 10-volt range; however, the linear portion of the 3-volt scale can be used as a modulation indicator since the 1-volt calibration mark now represents 0% modulation and the 2-volt calibration will represent 100% modulation, with the intermediate calibrations corresponding to the calibrations on the PERCENT MODULATION meter in the signal generator. Accuracy of modulation indication as read from the 410B Voltmeter will be approximately $\pm 5\%$ or better.

- f. Adjust the MOD. LEVEL control for a reading corresponding to 1.8 on the 410B voltmeter.
 g. Application of high percentages of modulation may result in a slight rise (1/2 db) in the OUTPUT VOLTS meter indication. If necessary, re-adjust the OUTPUT LEVEL control to obtain a reading at SET LEVEL on the OUTPUT VOLTS meter.
 h. Adjust R104 (see Figure 4-8) to provide a reading of 80% on the PERCENT MODULATION meter.
 i. Check the meter calibration for other modulation percentages, e.g., 1.1 on the voltmeter corresponds to 10% modulation, 1.2 to 20%, etc. The setting of R104 may be refined to obtain best overall calibration accuracy of the PERCENT MODULATION meter.

NOTE: For this procedure the OUTPUT LEVEL control must be set at all times to provide a reading at SET LEVEL on the OUTPUT VOLTS meter.

4-13 OUTPUT VOLTS METER CALIBRATION AND R-F POWER MONITOR SERVICE

Recalibration of the OUTPUT VOLTS meter may be necessary following replacement of the attenuator probe, components in the power monitoring circuits, or replacement of the meter itself. If it becomes necessary to replace CR2 or R60 in the power monitor assembly, the frequency response of the meter circuit will also be affected and must be readjusted.

CAUTION: Do not disturb the positioning of the components in the r-f power monitor assembly (see Figure 4-10) until instructed to do so in procedure. The position and lead lengths of resistor R60 and L17 and the characteristics of crystal CR2 all affect the frequency response of the meter circuit, mostly on the E band and to a lesser degree on the D band. To restore "flat" frequency response requires care and skill in repositioning.

The method of calibration outlined below requires the use of a 50-ohm bolometer mount and power meter, such as the Ⓜ Model 476A Universal Bolometer Mount and Ⓜ Model 430C Power Meter, to measure the r-f signal power from the generator. To reset the frequency response of the higher bands, such as following replacement of CR2 or R60, the OUTPUT VOLTS meter must first be checked for accuracy as described in steps a. through i. below, then adjusted as described in step j. Proceed as follows:

a. Connect the 608C to a source of 115-volt a-c power. Turn on the power switch and allow to warm up with the operating controls in the following positions:

- MOD. SELECTOR - CW
- FREQUENCY CONTROL - 75 to 80 megacycles
- FREQUENCY RANGE - C band
- AMP. TRIMMER - Adjust for max. output
- OUTPUT LEVEL - Adjust for SET LEVEL
- MOD. LEVEL - Extreme ccw
- Attenuator - 0 dbm

b. Connect the power meter and bolometer mount to the RF OUTPUT jack on the signal generator.

c. With the attenuator set for exactly 0 dbm, adjust the OUTPUT LEVEL control to obtain exactly 1 milliwatt (1 dbm) on the external power meter.

d. If necessary, adjust R62 to obtain an exact reading at SET LEVEL on the self-contained OUTPUT VOLTS meter.

e. Using the db scale of the OUTPUT VOLTS meter, check the +4 and +13 calibration points with the external power meter (points -3 and +6 db from SET LEVEL where calibration took place).

f. Adjust the OUTPUT LEVEL control for -3 dbm as read on the external power meter. If necessary, adjust R62 to obtain a reading of +4 db on the self-contained OUTPUT VOLTS meter.

g. Set OUTPUT LEVEL control for +6 dbm as read on the external power meter. If necessary, adjust R61 to obtain a reading of +13 db on the self-contained OUTPUT VOLTS meter.

h. Because the two adjustments R61 and R62 are inter-active, steps f. and g. must be repeated to obtain best overall accuracy of calibration.

i. Recheck accuracy of calibration at SET LEVEL (0 dbm on the external power meter) and, if necessary, adjust R62 to obtain an exact reading at this point.

j. Recheck calibration at SET LEVEL at frequencies of 100, 250, and 400 megacycles. If the calibration is high or low at the higher frequencies, the OUTPUT VOLTS meter reading may be corrected by adjusting the inductance of L17. Shortening the coil (increasing the inductance) will decrease the meter reading as shown in the diagram below. Lengthening the coil (decreasing the inductance) will increase the meter reading.

CAUTION: Great care should be taken to change only the length of the coil and not to shift the positions of any other components in the power monitor assembly.

If the frequency response is satisfactory at all frequencies up to approximately 300 mc but tends to rise or fall at the higher frequencies, the pigtail connection of resistor R60 which connects to coil L17 may be adjusted very slightly to raise or lower the meter reading at the higher frequencies only. Again, great care must be used to adjust the positioning of only one component at a time and to follow each adjustment with a power measurement to see the exact effect of the adjustment. In general, increasing the capacity between this pigtail and ground may be expected to decrease the meter reading at only the higher frequencies.

The graph below shows the increase or decrease in the reading of the OUTPUT VOLTS meter that is obtained at different frequencies when making each one of the three possible adjustments. Only very small adjustments should be made (very small change in physical position), using the graph for a guide as to the approximate results that may be expected.

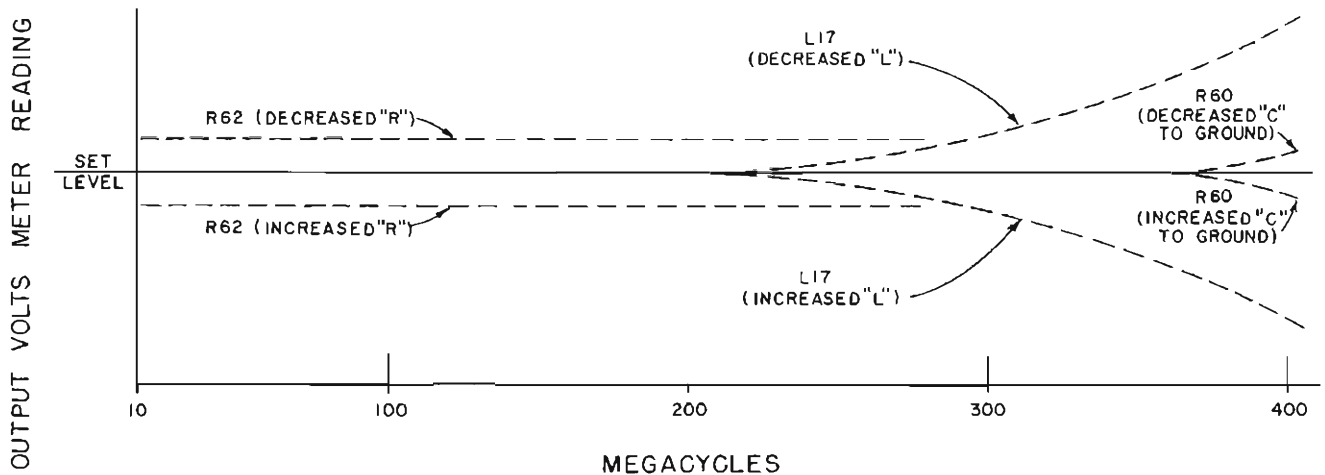

4-14 TROUBLE SHOOTING CHART

SYMPTOM	POSSIBLE TROUBLE	SUGGESTED CHECK AND REMEDY
<p>1. A. Low r-f output (cannot obtain full-scale reading on output level meter).</p> <p>B. No r-f output (output level meter indicates normal output).</p> <p>C. Low cw output at low frequency end of the E band.</p> <p>D. Intermittent operation on any one band.</p>	<p>Low heater voltage from V17. Weak oscillator V6. Weak amplifier V8.</p> <p>Low power supply voltage.</p> <p>Open attenuator impedance-matching network.</p> <p>Weak V6. Weak V8.</p> <p>Poor connections at contacts on oscillator or amplifier coil turrets.</p>	<p>Check heater voltage. If necessary, set to 7 volts as described in paragraph 4-10. Check V6 and V7 by measurement of r-f signal at cathode of V8 in tube compartment. Should be 4 to 11 volts. Replace tubes to improve.</p> <p>Check the +225 volt and the -165 volt supplies.</p> <p>Check resistance of attenuator at output jack. Should be 50 ohms.</p> <p>Check by replacing V6.</p> <p>Check by replacing V8.</p> <p>Clean contacts. If necessary, bend turret contact slightly for greater pressure.</p>
<p>2. Output signal cannot be reduced by OUTPUT LEVEL control (output meter remains upscale).</p>	<p>Weak V5.</p>	<p>Check by replacing V5.</p>
<p>3. Frequency calibration inaccurate at high frequency ends of all bands.</p>	<p>Tube characteristic differences following replacement of V6.</p>	<p>Adjust C18 for correct calibration at top of all bands. See paragraph 4-7.</p>
<p>4. A. Output level drifts.</p> <p>B. Output level drifts (with changes in line voltage).</p> <p>C. High residual hum on output signal may be read on PERCENT MODULATION meter when no modulation is applied.</p>	<p>Weak V6.</p> <p>Power supply does not regulate properly.</p> <p>Same as above.</p>	<p>Check V6 by replacing.</p> <p>Check stability of regulated +225- and -165-volt supplies. Check V12 and V13 for defective +225-volt supply and V14 and V16 for defective -165-volt supply.</p> <p>Same as above.</p>

TROUBLE SHOOTING CHART (CONT'D.)

SYMPTOM	POSSIBLE TROUBLE	SUGGESTED CHECK AND REMEDY
5. Little or no indication from output meter, output signal normal.	Check meter M1. Check crystal diode CR2 and refer to "CAUTION" on pages IV-11 and IV-12 (paragraph 4-13).	If necessary, replace M1 or CR2 and recheck calibration of OUTPUT VOLTS meter. If necessary, adjust R62 (see paragraph 4-13) for best accuracy.
6. Change in mod. percent causes change in output level meter. (About 10% is normal at high modulation percentages.)	Overmodulation can be due to actual r-f signal being less than indicated amount or due to modulation being greater than indicated amount.	Check amplitude of r-f output signal with external output meter. Check modulation of r-f carrier by viewing on oscilloscope. Check gain of modulation indicator amplifier.
7. Distortion of the modulation envelope, particularly at high modulation levels.	Weak r-f power amplifier V8. Weak r-f oscillator V6. Distorted modulating wave from oscillator V2 or amplifier V3.	Check by replacement of V8. Check r-f drive to power amplifier. Should be 4 to 11 volts. Check distortion of the modulating sine wave from modulator V5.
8. No internal modulation signal.	Loose 3-watt lamp I1 in modulation oscillator V2.	Tighten lamp in socket.
9. RF output signal does not go zero when generator is switched to PULSE operation and no pulses are applied.	Weak cathode follower V4 in modulator.	Replace V4.

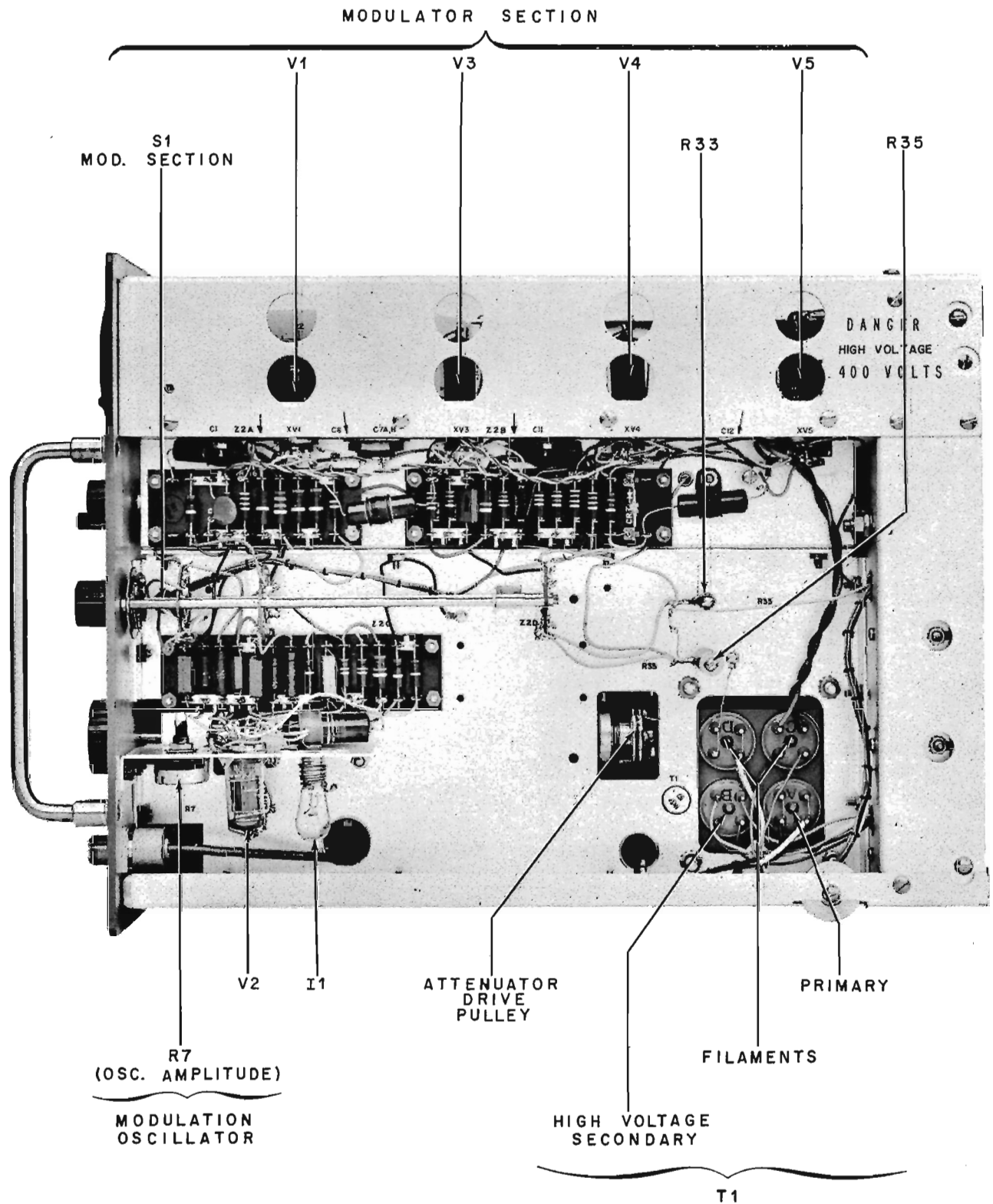

Figure 4-7. Signal Generator Model 608C Right Side View, Cabinet Removed

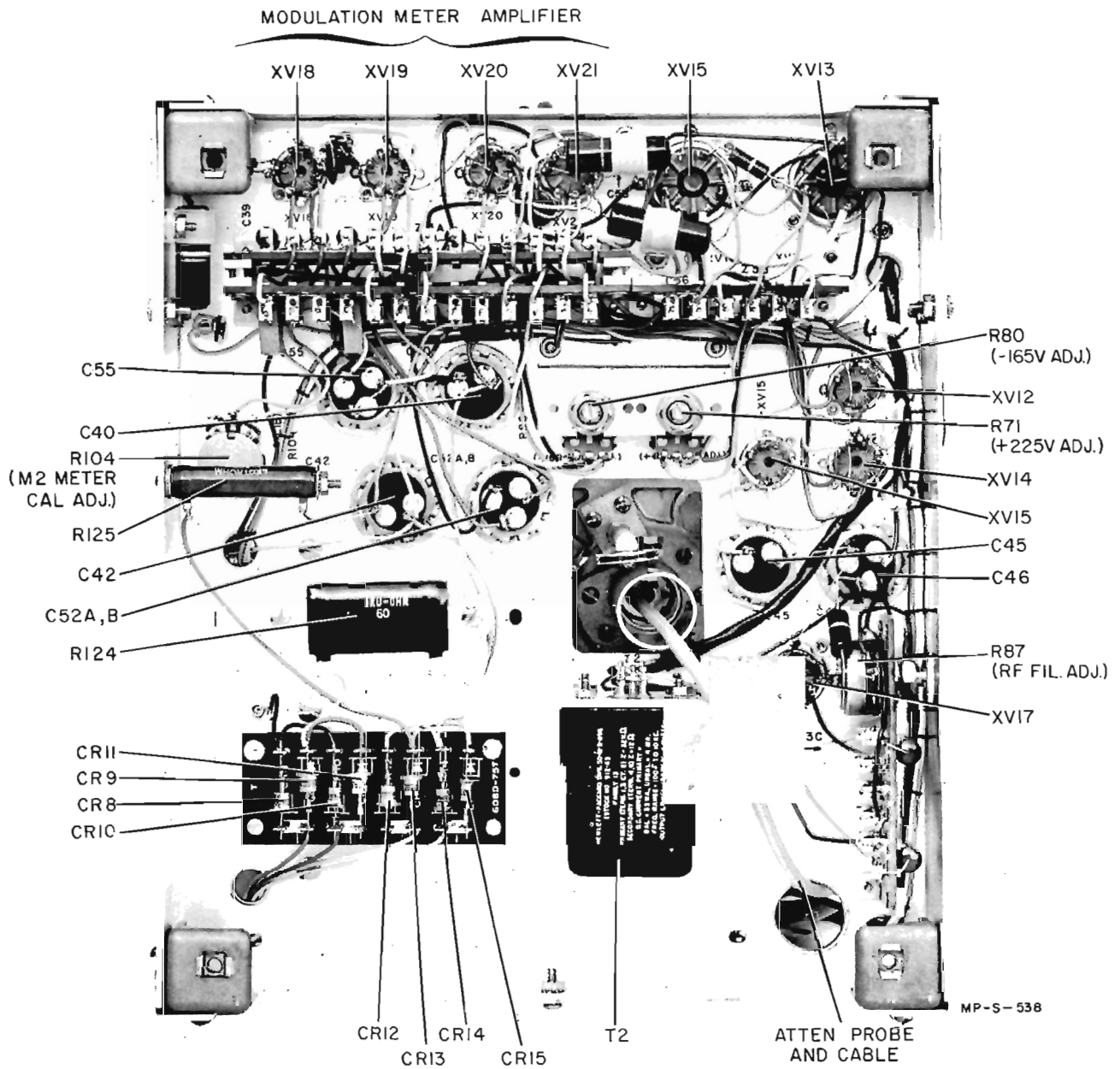

Figure 4-8. Signal Generator Model 608C Rear View, Cabinet Removed

POWER SUPPLY
(REAR CHASSIS)

RF GENERATOR ASSEMBLY
(TUBE COMPARTMENT)

OUTPUT
ATTEN. CABLE

RF AMPLIFIER
TUNING COMPARTMENT

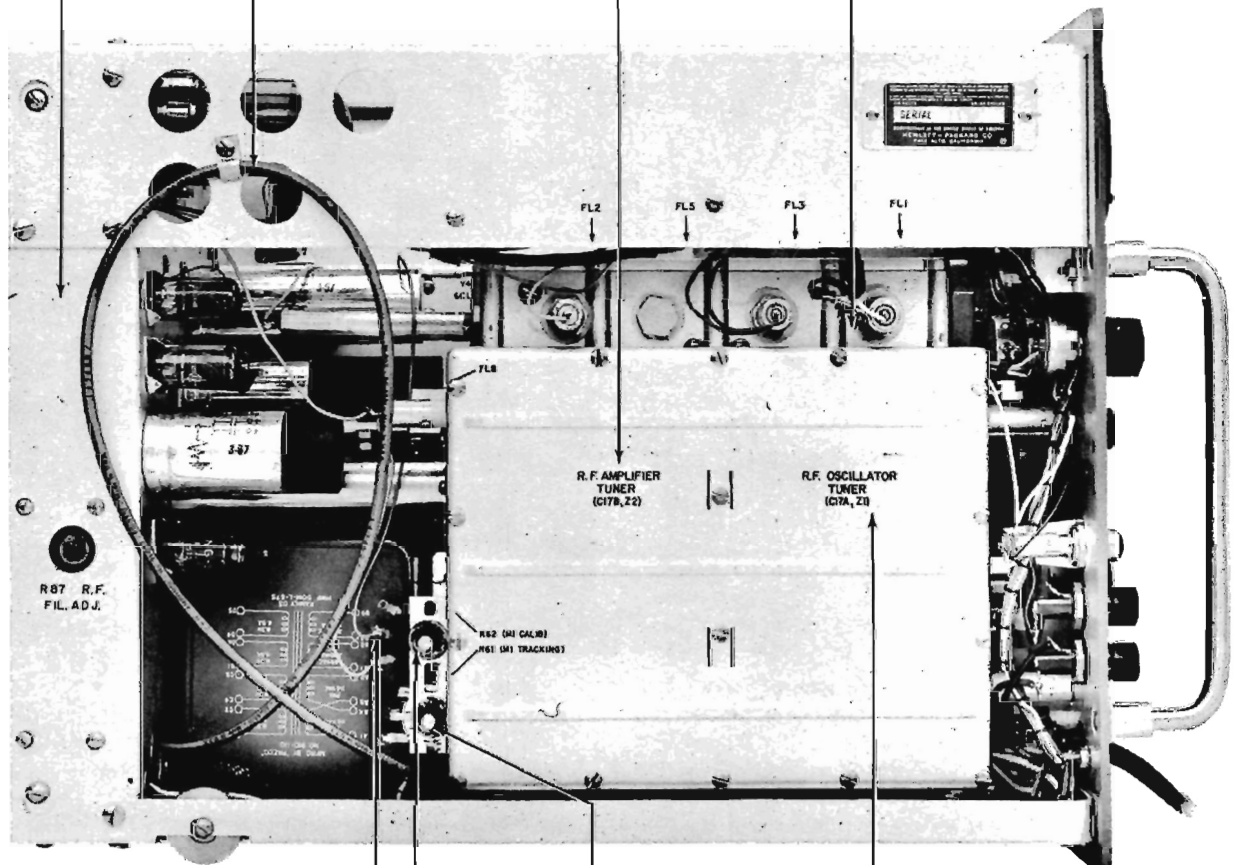

R87 R.F.
FIL. ADJ.

R.F. AMPLIFIER
TUNER
(C17B, Z2)

R.F. OSCILLATOR
TUNER
(C17A, Z1)

R61
METER TRACKING
ADJ.

R62
METER CALIB.
ADJ.

RF OSCILLATOR
TUNING COMPARTMENT

CR3

Figure 4-9. Signal Generator Model 608C Left Side View,
Cabinet Removed

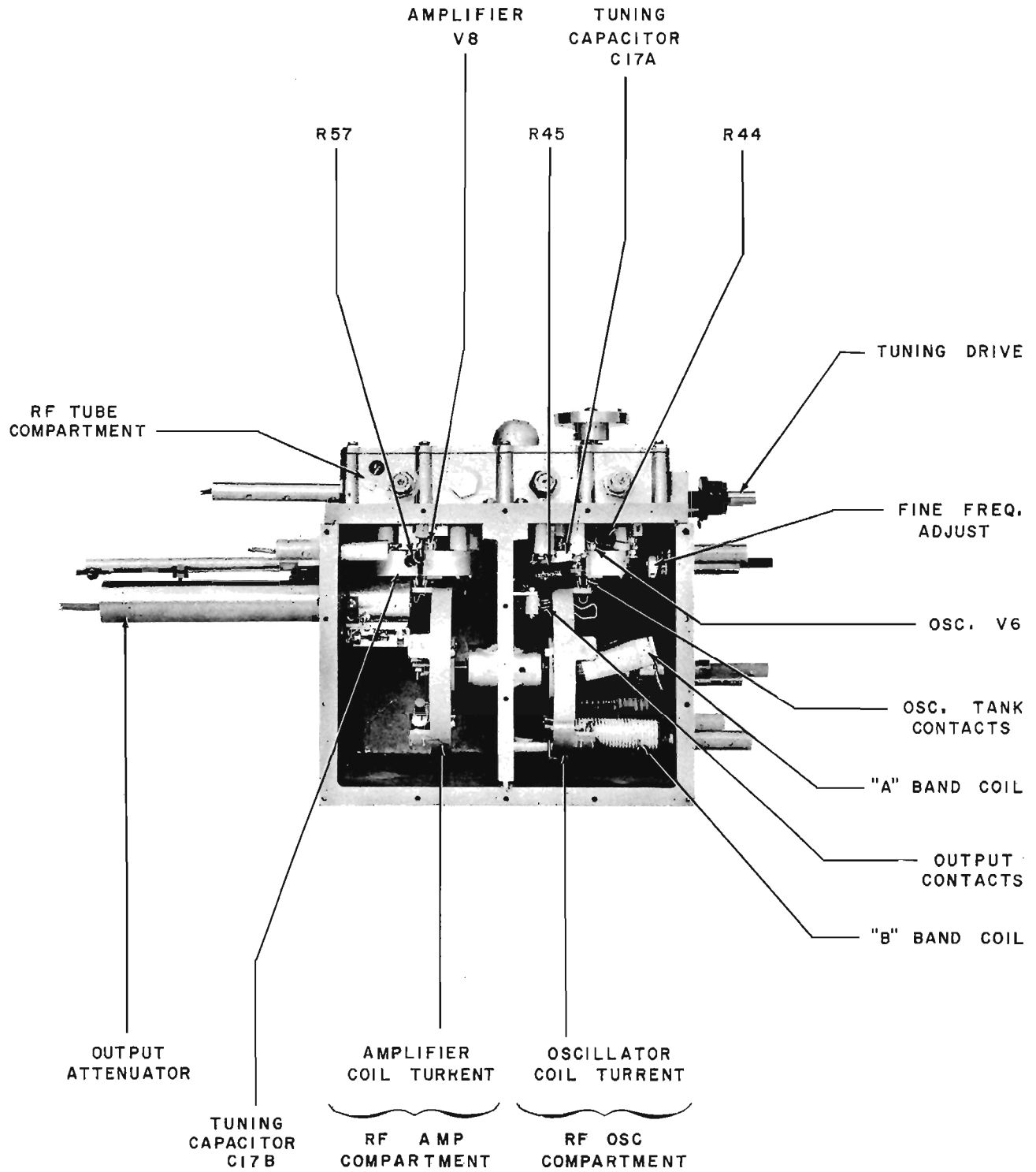

Figure 4-10. R-F Generator Assembly,
Side Plate Removed to Show Tuning Compartments

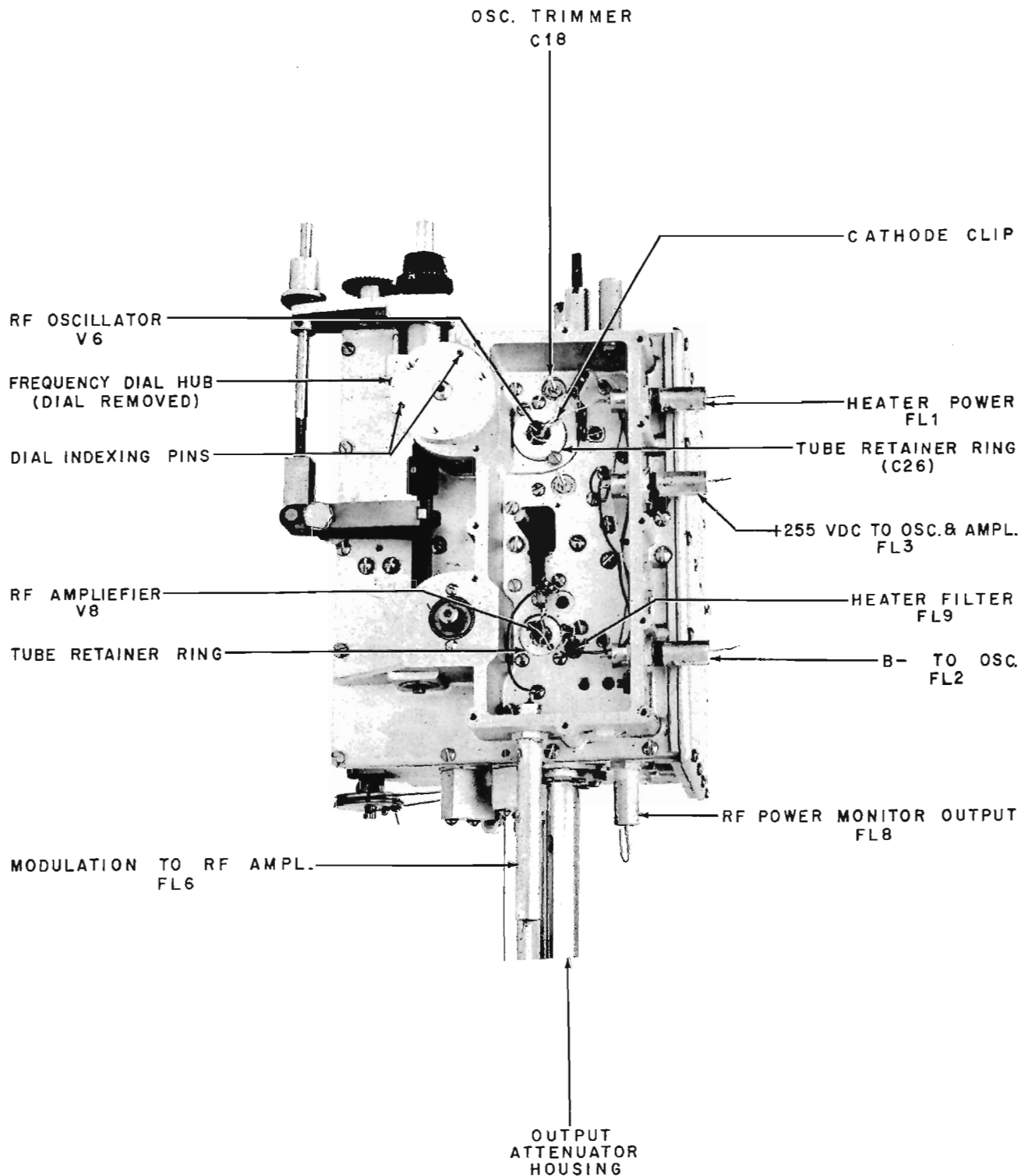

Figure 4-11. Tube Compartment of R-F Generator Assembly,
Frequency Dial and Cover Plate Removed

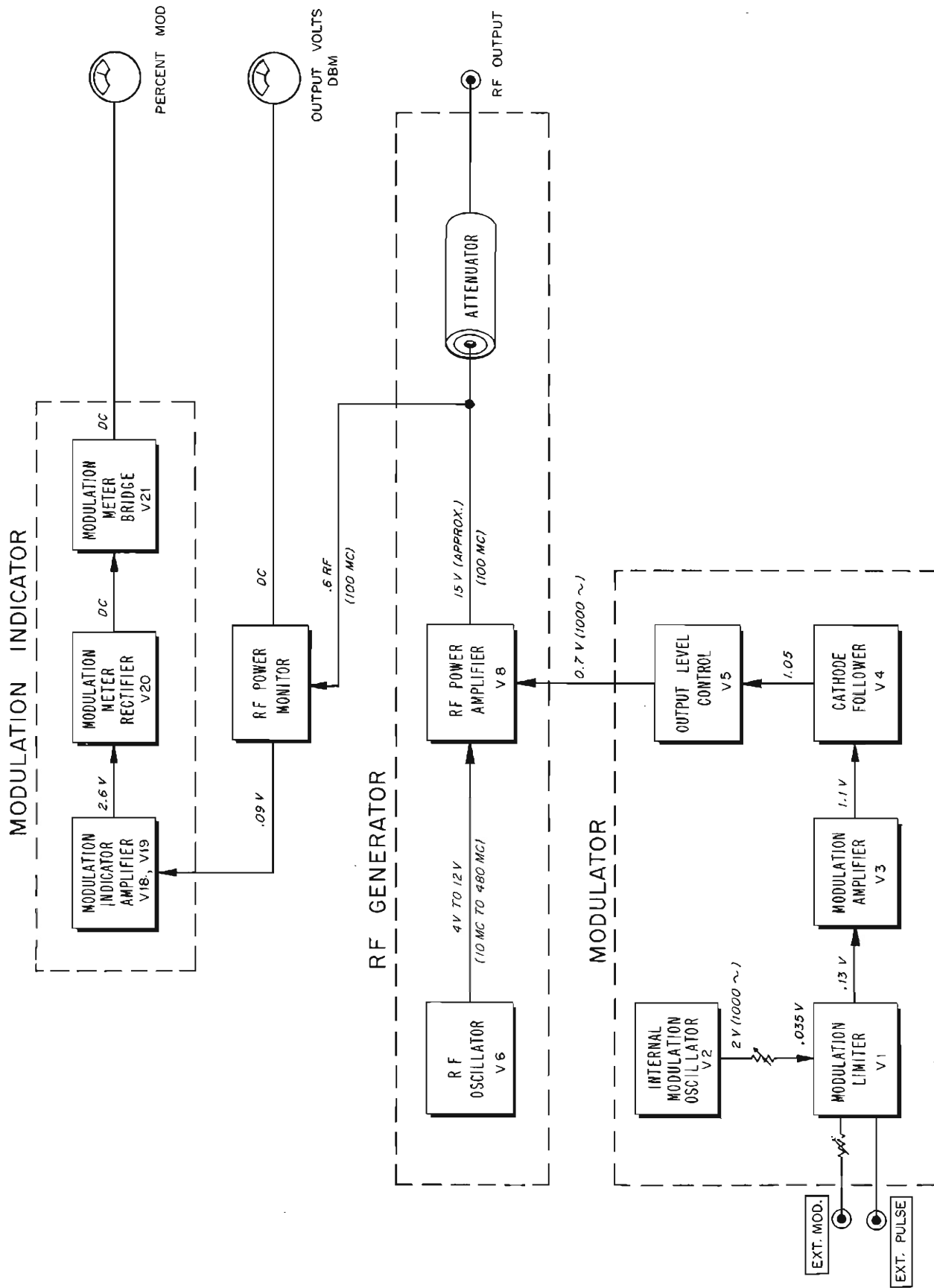

Figure 4-12. Signal Tracing Block Diagram

NOTES PERTAINING TO TUBE SOCKET VOLTAGE-RESISTANCE DIAGRAMS

1. CONDITIONS OF MEASUREMENT

Unless otherwise noted, measurements made with respect to chassis ground using voltmeter having 20,000-ohm-per-volt sensitivity and with front panel controls at the following settings:

FREQUENCY	100 MC
MOD. SELECTOR	1000 ν
MOD. LEVEL	30 %
OUTPUT LEVEL	Set Level

R71 and R80 in the power supply section were set to provide the normal supply voltages of +225V and -165V, respectively.

2. 20,000-ohm-per-volt meter cannot be used for this measurement since it will load the circuit and provide an erroneous reading. A vacuum-tube voltmeter should be used here.
(Note referenced on Figures 4-13, 4-14.)
3. Reading taken at minimum and maximum setting of OUTPUT LEVEL control.
(Note referenced on Figures 4-13, 4-15.)
4. Voltages measured with respect to -165V bus.
(Note referenced on Figure 4-14.)
5. Resistance to ground with MOD. SELECTOR at:

CW	∞
PULSE	2 K
400 ν , 1000 ν , EXT. MOD.	28 K

(Note referenced on Figure 4-13.)

_____ = EXTERNAL STRAP

----- = INTERNAL CONNECTION

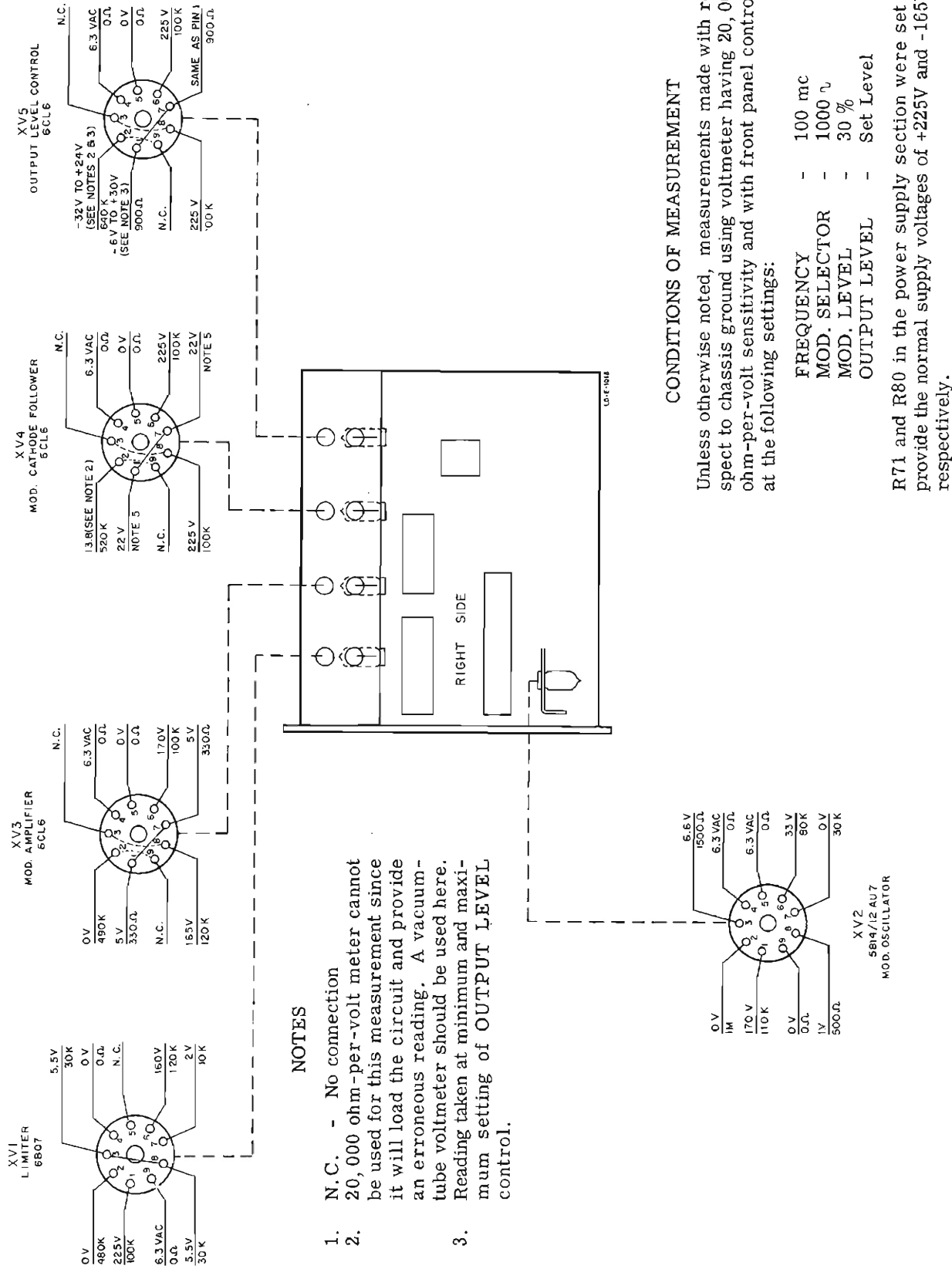
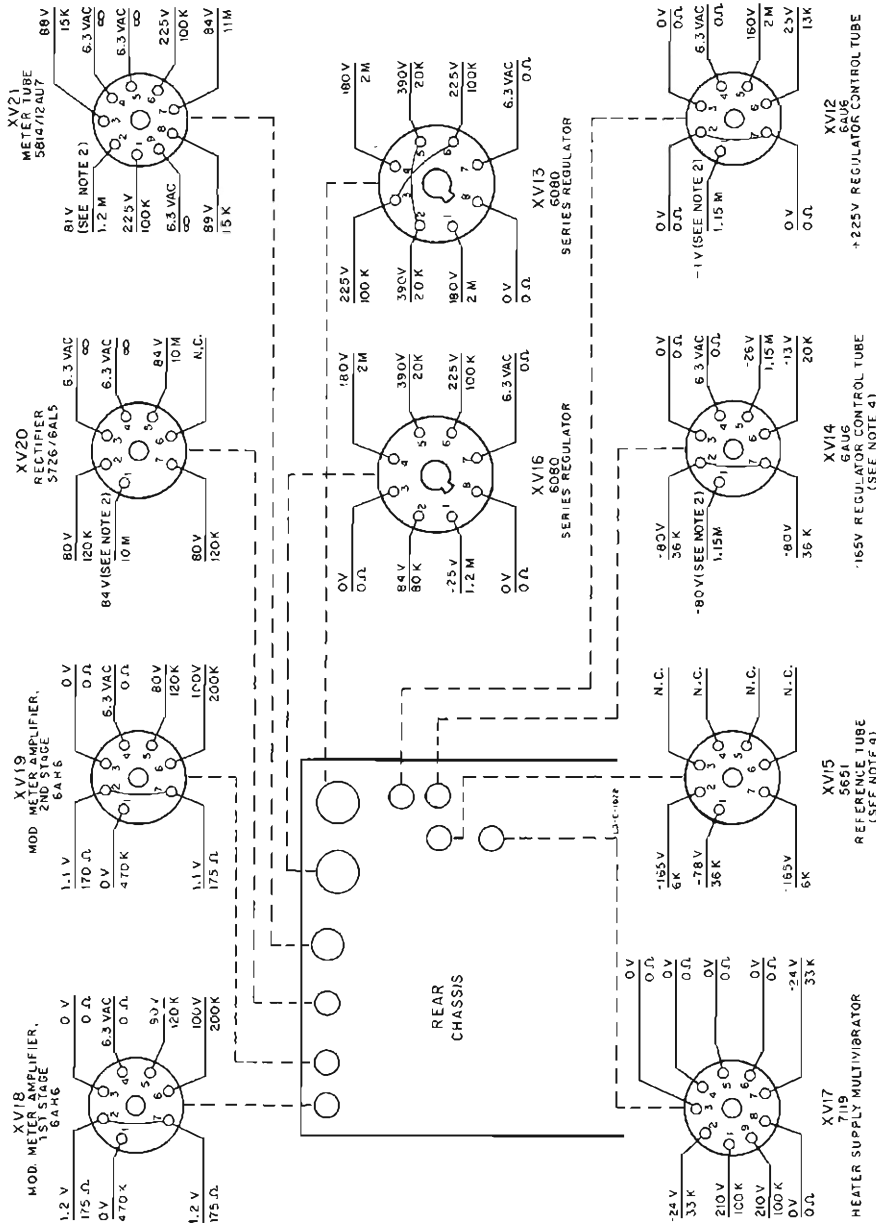

Figure 4-13. Voltage and Resistance Diagram for Tube Sockets Located on Right Side Chassis



NOTES

1. N.C. - No connection
2. 20,000-ohm-per-volt meter cannot be used for this measurement since it will load the circuit and provide an erroneous reading. A vacuum-tube voltmeter should be used here.

CONDITIONS OF MEASUREMENTS:

Unless otherwise noted, measurements made with respect to chassis ground using voltmeter having 20,000 ohm-per-volt sensitivity and with front panel controls at the following settings:

- FREQUENCY - 100 mc
- MOD. SELECTOR - 1000 Ω
- MOD. LEVEL - 30%
- OUTPUT LEVEL - Set Level

R71 and R80 in the power supply section were set to provide the normal supply voltages of +225V and -165V, respectively.

Figure 4-14. Voltage and Resistance Diagram for Tube Sockets Located on Rear Chassis

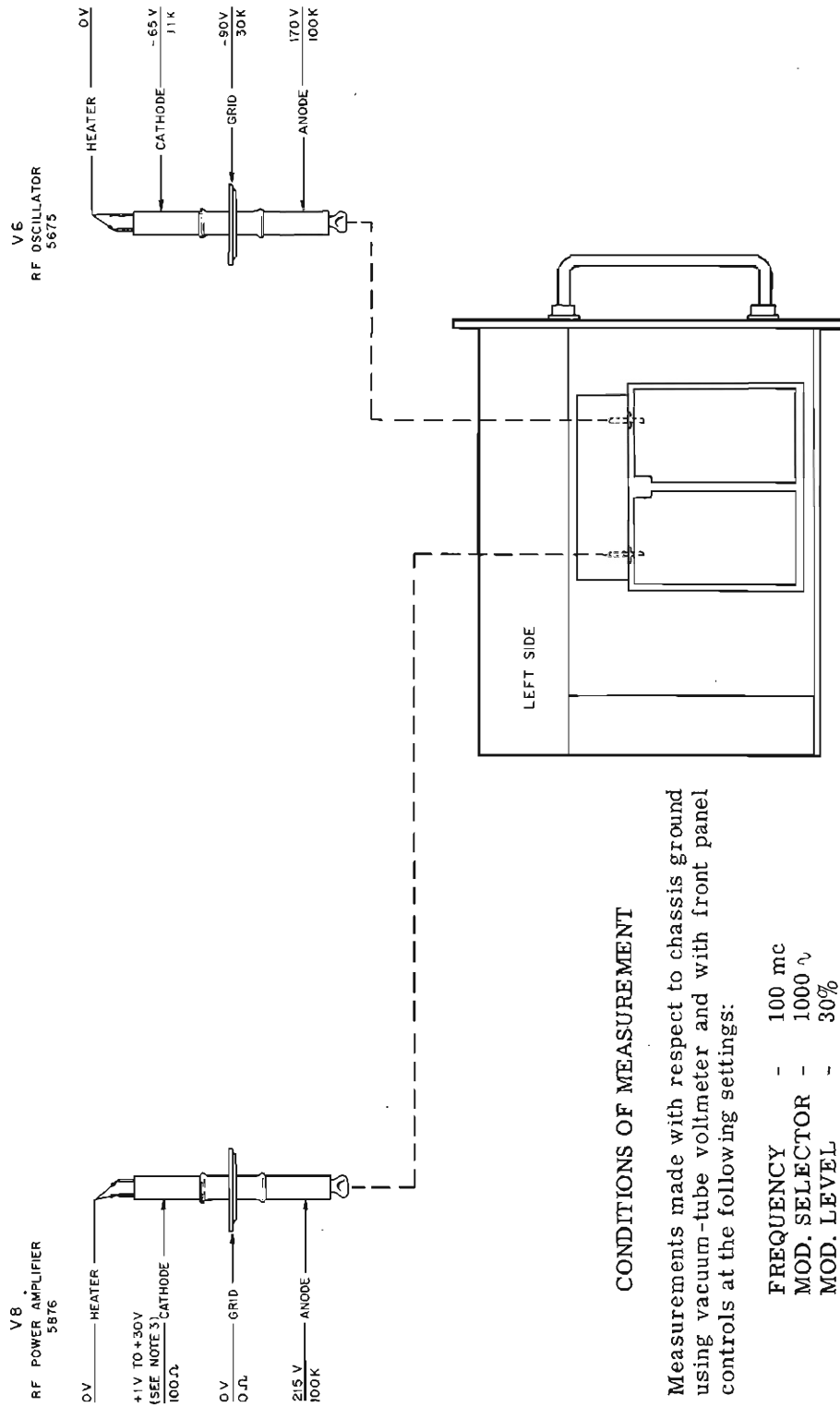

CONDITIONS OF MEASUREMENT

Measurements made with respect to chassis ground using vacuum-tube voltmeter and with front panel controls at the following settings:

- FREQUENCY - 100 mc
- MOD. SELECTOR - 1000 λ
- MOD. LEVEL - 30%
- OUTPUT LEVEL - Set Level

NOTES

Readings taken at minimum and maximum setting of OUTPUT LEVEL control.

Figure 4-15. Voltage and Resistance Diagram for R-F Generator Assembly

NOTES

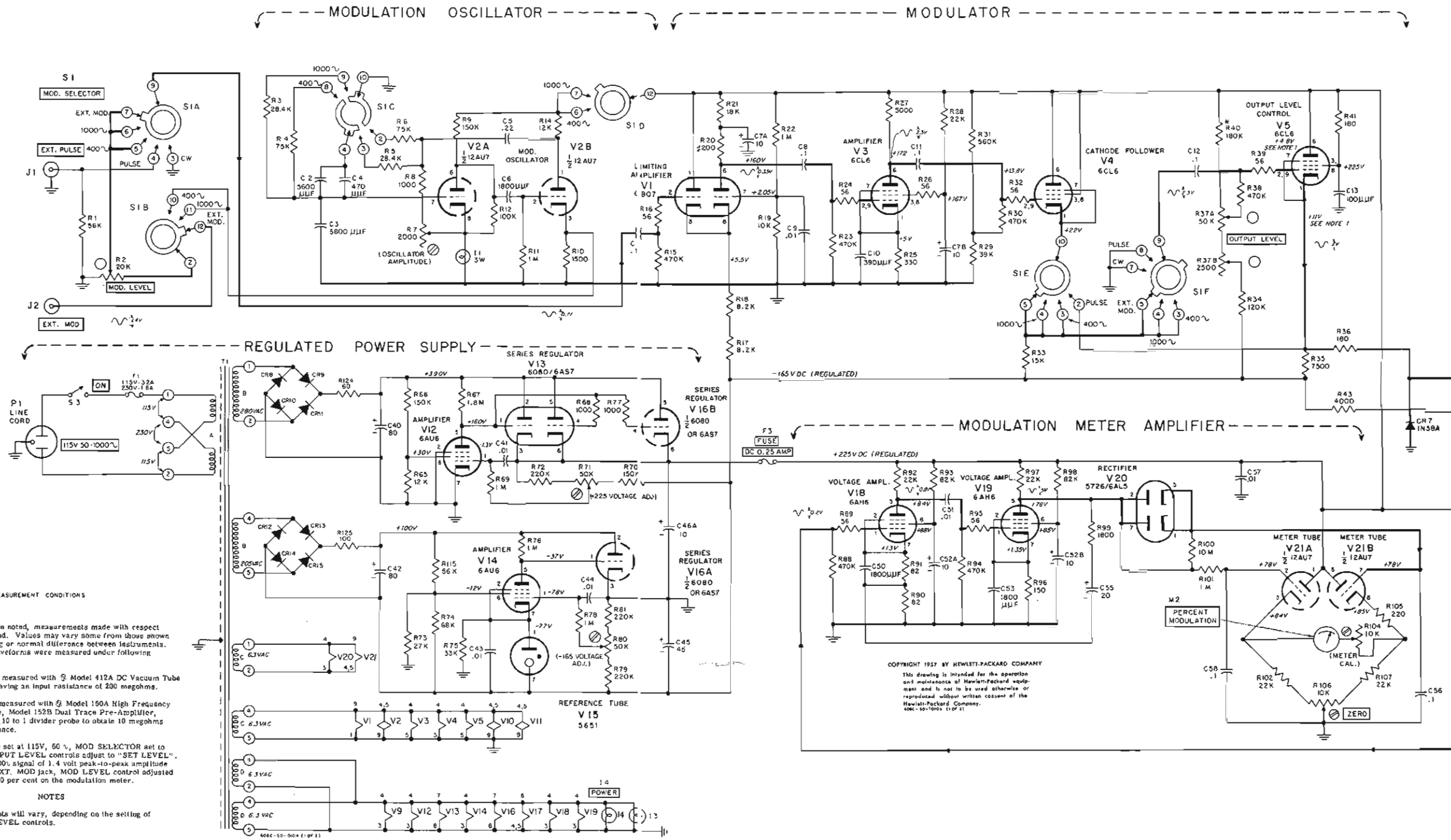

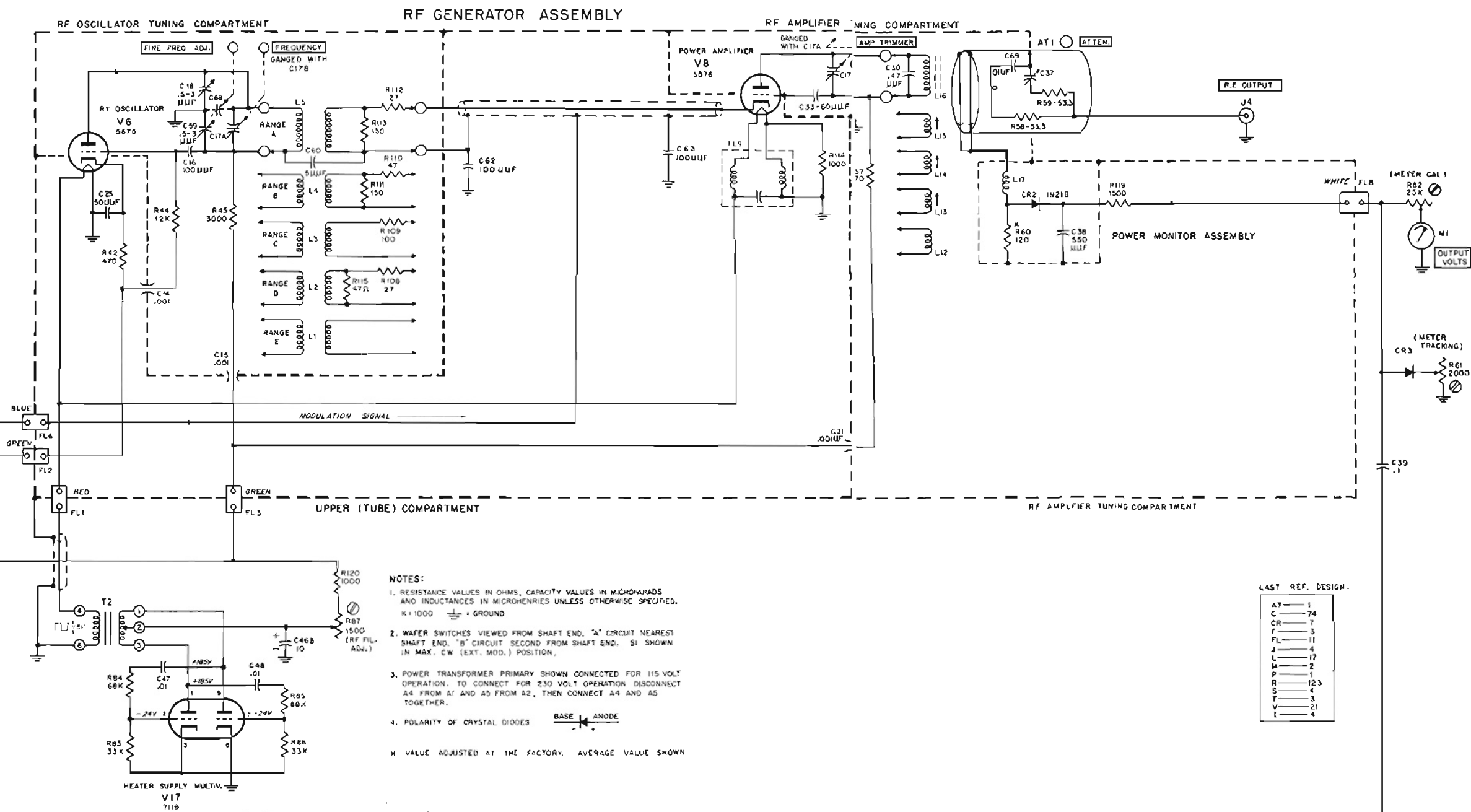

COPYRIGHT 1957 BY HEWLETT-PACKARD COMPANY
 This drawing is intended for the operation and maintenance of Hewlett-Packard equipment and is not to be used otherwise or reproduced without written consent of the Hewlett-Packard Company 1001-10-100012-2

SECTION V

TABLE OF REPLACEABLE PARTS

NOTE

Standard components have been used in this instrument, whenever possible. Special components may be obtained from your local Hewlett-Packard representative or from the factory.

When ordering parts always include:

1.  Stock Number.
2. Complete description of part including circuit reference.
3. Model number and serial number of instrument.
4. If part is not listed, give complete description, function and location of part.

Corrections to the Table of Replaceable Parts are listed on an Instruction Manual Change sheet at the front of this manual.

RECOMMENDED SPARE PARTS LIST

Column RS in the Table lists the recommended spare parts quantities to maintain one instrument for one year of isolated service. Order complete spare parts kits from the Factory Parts Sales Department. ALWAYS MENTION THE MODEL AND SERIAL NUMBERS OF INSTRUMENTS INVOLVED.

TABLE OF REPLACEABLE PARTS

Circuit Ref.	Description	Mfr. *	Ⓟ Stock No.	TQ	RS		
AT1	Attenuator Probe Assembly with cable and panel jack	28480	608D-34	1	1		
C1	Capacitor: fixed, paper 0.1 μ f, $\pm 10\%$, 400 vdcw	56289	0160-0013	7	2		
C2, 3	Capacitor: fixed, mica 5600 pf, $\pm 10\%$, 500 vdcw	00656	0140-0071	2	1		
C4	Capacitor: fixed, silver mica, 470 pf, $\pm 5\%$, 500 vdcw	00853	0140-0085	1	1		
C5	Capacitor: fixed, paper, 0.22 μ f, $\pm 10\%$, 400 vdcw	56289	0160-0018	1	1		
C6	Capacitor: fixed, mica 1800 pf, $\pm 10\%$, 500 vdcw	00853	0140-0020	3	1		
C7A, B	Capacitor: fixed, electrolytic dual section. 2 x 10 μ f, 450 vdcw	14655	0180-0018	4	1		
C8	Same as C1						
C9	Capacitor: fixed, ceramic, .01 μ f, $\pm 20\%$ 1000 vdcw	56289	0150-0012	6	2		
C10	Capacitor: fixed, mica, 390 pf, $\pm 5\%$, 500 vdcw	00853	0140-0016	1	1		
C11, 12	Same as C1						
C13	Capacitor: fixed, mica, 100 pf, $\pm 10\%$, 500 vdcw	00853	0140-0054	1	1		
C14, 15	Capacitor: fixed, ceramic, 1000 pf, $\pm 20\%$, 500 vdcw	72982	0150-0019	3	1		
C16	Capacitor: fixed, ceramic, 100 pf, $\pm 10\%$, 500 vdcw	56289	0150-0028	1	1		
C17, A, B	This capacitor is not a field replacement item						
C18	Capacitor: variable, glass 0.5-3 pf	07115	0133-0001	2	1		
C19 thru C24	Not assigned						
C25	Capacitor assembly: fixed, mica, approx. 50 pf	28480	608D-95D	2	1		

* Refer to "List of Manufacturers' Codes".

TQ Total Quantity used in the instrument.

RS Recommended spares for one year isolated service for one instrument.

TABLE OF REPLACEABLE PARTS

Circuit Ref.	Description	Mfr. *	Stock No.	TQ	RS		
C26 thru C29	Not assigned						
C30	Capacitor: fixed, titanium dioxide, .47 pf, $\pm 5\%$, 500 vdcw	78488	0150-0021	1	1		
C31	Same as C14						
C32	Not assigned						
C33	Capacitor: fixed, mica, 60 pf, $\pm 10\%$, 500 vdcw	28480	608D-82	1	1		
C34 thru C36	Not assigned						
C37	Part of Attenuator Assembly						
C38	Capacitor: fixed, silver mica, 550 pf, $\pm 10\%$, 500 vdcw	00853	0140-0069	1	1		
C39	Same as C1						
C40	Capacitor: fixed, electrolytic, 80 μ f, 450 vdcw	14655	0180-0020	2	1		
C41	Same as C9						
C42	Same as C40						
C43, 44	Same as C9						
C45	Capacitor: fixed, electrolytic, 45 μ f, 450 vdcw	14655	0180-0019	1	1		
C46A, B	Same as C7A, B						
C47, 48	Capacitor: fixed, paper, .01 μ f, $\pm 10\%$, 600 vdcw	56289	0160-0002	2	1		
C49	Not assigned						
C50	Same as C6						
C51	Same as C9						
C52A, B	Same as C7A, B						
C53	Same as C6						
C54	Not assigned						

* Refer to "List of Manufacturers' Codes".

TQ Total Quantity used in the instrument.

RS Recommended spares for one year isolated service for one instrument.

TABLE OF REPLACEABLE PARTS

Circuit Ref.	Description	Mfr. *	Ⓟ Stock No.	TQ	RS		
C55	Same as C7A, B						
C56	Same as C1						
C57	Same as C9						
C58	Same as C1						
C59	Same as C18						
C60	Capacitor: fixed, ceramic, 5 pf ±10%, 500 vdcw	04222	0150-0008	1	1		
C61	Not assigned						
C62, 63	Capacitor: fixed, mica, 100 pf ±10%, 500 vdcw	00853	0140-0077	2	1		
C64 thru C68	Not assigned						
C69	Capacitor: fixed, mylar, Part of Attenuator Probe Assembly (AT1)						
CR1	Not assigned						
CR2	Diode, crystal: 1N21B	96341	1900-0001	1	1		
CR3	Diode, crystal: germanium	73293	1910-0011	1	1		
CR4, 5, 6	Not assigned						
CR7	Diode, germanium: 1N38A	93332	1910-0002	1	1		
CR8 thru CR11	Rectifier, silicon, 500V, PIV 500 ma Type SD500	81483	1901-0009	4	4		
CR12 thru CR15	Rectifier: silicon, 400V PIV 500 ma type SD-95A	81483	1901-0007	4	4		
F1	Fuse, cartridge: 3.2 amp, slow blow, 115V operation	75915	2110-0013	1	10		
	Fuse, cartridge: 1.6 amp slow blow, 230V operation	71400	2110-0005				
F2	Not assigned						

* Refer to "List of Manufacturers' Codes".

TQ Total Quantity used in the instrument.

RS Recommended spares for one year isolated service for one instrument.

TABLE OF REPLACEABLE PARTS

Circuit Ref.	Description	Mfr. *	Stock No.	TQ	RS		
F3	Fuse, cartridge: 1/4 amp	75915	2110-0004	1	10		
FL1	Filter, R.F.: "A", red	28480	608A-27A	1	1		
FL2, 3	Filter, R.F.: "D", green	28480	608A-27D	2	1		
FL4, 5	Not assigned						
FL6	Filter, R.F.: blue	28480	608D-27C	1	1		
FL7	Not assigned						
FL8	Filter, R.F.: white	28480	608D-27B	1	1		
FL9	Filter, R.F.: choke (includes R114)	28480	608D-60M	1	1		
I1	Lamp , incandescent: 120V, 3 W	24455	2140-0001	1	1		
I2	Not assigned						
I3, 4	Lamp, incandescent: 6-8V, .15 amp, #47	24455	2140-0009	2	1		
J1, 2	Connector, female: type BNC (EXT PULSE, EXT MOD)	91737	1250-0001	2	1		
J3	Not assigned						
J4	Part of Attenuator Probe Assembly (AT1)						
L1 thru L5	Part of Oscillator Turret Assembly replace as a unit						
L6 thru L11	Not assigned						
L12 thru L16	Part of Amplifier Turret Assembly replace as a unit						
L17	Part of Power Monitor Assembly						
M1	Meter, output	65092	1120-0039	1	1		
M2	Meter, modulation	65092	1120-0040	1	1		
P1	Cable, power	70903	8120-0015	1	1		

* Refer to "List of Manufacturers' Codes".

TQ Total Quantity used in the instrument.

RS Recommended spares for one year isolated service for one instrument.

TABLE OF REPLACEABLE PARTS

Circuit Ref.	Description	Mfr. *	Ⓟ Stock No.	TQ	RS		
R1	Resistor: fixed, composition, 56,000 ohms $\pm 10\%$, 1 W	01121	0690-5631	1	1		
R2	Resistor: variable, composition, 20,000 ohms $\pm 10\%$, 1/3 W	71450	2100-0160	1	1		
R3	Resistor: fixed, deposited carbon, 28,400 ohms $\pm 1\%$, 1/2 W	19701	0727-0184	2	1		
R4	Resistor: fixed, deposited carbon, 75,000 ohms $\pm 1\%$, 1 W	19701	0730-0058	2	1		
R5	Same as R3						
R6	Same as R4						
R7	Resistor: variable, composition, 2000 ohms $\pm 20\%$	12697	2100-0010	2	1		
R8	Resistor: fixed, composition, 1000 ohms $\pm 10\%$, 1 W	01121	0690-1021	3	1		
R9	Resistor: fixed, composition, 150,000 ohms $\pm 10\%$, 1 W	01121	0690-1541	3	1		
R10	Resistor: fixed, composition, 1500 ohms $\pm 10\%$, 1 W	01121	0690-1521	2	1		
R11	Resistor: fixed, composition, 1 megohm $\pm 10\%$, 1 W	01121	0690-1051	6	2		
R12	Resistor: fixed, composition, 100,000 ohms $\pm 10\%$, 1 W	01121	0690-1041	1	1		
R13	Not assigned						
R14	Resistor: fixed, composition, 12,000 ohms $\pm 10\%$, 2 W	01121	0693-1231	2	1		
R15	Resistor: fixed, composition, 470,000 ohms $\pm 10\%$, 1 W	01121	0690-4741	4	1		
R16	Resistor: fixed, composition, 56 ohms $\pm 10\%$, 1/2 W	01121	0687-5601	7	2		
R17, 18	Resistor: fixed, composition, 8200 ohms $\pm 10\%$, 2 W	01121	0693-8221	2	1		
R19	Resistor: fixed, composition, 10,000 ohms $\pm 10\%$, 1 W	01121	0690-1031	1	1		

* Refer to "List of Manufacturers' Codes".

TQ Total Quantity used in the instrument.

RS Recommended spares for one year isolated service for one instrument.

TABLE OF REPLACEABLE PARTS

Circuit Ref.	Description	Mfr. *	Ⓢ Stock No.	TQ	RS		
R20	Resistor: fixed, composition, 2200 ohms $\pm 10\%$, 2 W	01121	0693-2221	1	1		
R21	Resistor: fixed, composition, 18,000 ohms $\pm 10\%$, 2 W	01121	0693-1831	1	1		
R22	Same as R11						
R23	Same as R15						
R24	Same as R16						
R25	Resistor: fixed, composition, 330 ohms $\pm 10\%$, 1 W	01121	0690-3311	1	1		
R26	Same as R16						
R27	Resistor: fixed, wirewound, 5000 ohms $\pm 1\%$, 5 W	91637	0811-0006	1	1		
R28	Resistor: fixed, composition, 22,000 ohms $\pm 10\%$, 2 W	01121	0693-2231	5	2		
R29	Resistor: fixed, composition, 39,000 ohms $\pm 10\%$, 1 W	01121	0690-3931	1	1		
R30	Same as R15						
R31	Resistor: fixed, composition, 560,000 ohms $\pm 10\%$, 1 W	01121	0690-5641	1	1		
R32	Same as R16						
R33	Resistor: fixed, wirewound, 15,000 ohms $\pm 10\%$, 10 W	35434	0816-0013	1	1		
R34	Resistor: fixed, composition, 120,000 ohms $\pm 10\%$, 1 W	01121	0690-1241	1	1		
R35	Resistor: fixed, wirewound, 7500 ohms $\pm 5\%$, 20 W	35434	0818-0009	1	1		
R36	Resistor: fixed, composition, 180 ohms $\pm 10\%$, 1 W	01121	0690-1811	1	1		
R37A, B	Resistor: variable, carbon, 2 sections, 2000-50,000 ohms	12697	2100-0052	1	1		
R38	Same as R15						
R39	Same as R16						

* Refer to "List of Manufacturers' Codes".

TQ Total Quantity used in the instrument.

RS Recommended spares for one year isolated service for one instrument.

TABLE OF REPLACEABLE PARTS

Circuit Ref.	Description	Mfr. *	ϕ Stock No.	TQ	RS		
R40	Resistor: fixed, composition, 180,000 ohms $\pm 10\%$, 1 W Optimum value selected at factory Average value shown	01121	0690-1841	1	1		
R41	Resistor: fixed, composition, 180 ohms $\pm 10\%$, 1/2 W	01121	0687-1811	1	1		
R42	Resistor: fixed, composition, 470 ohms $\pm 10\%$, 2 W	01121	0693-4711	1	1		
R43	Resistor: fixed, wirewound, 4000 ohms $\pm 10\%$, 10 W	35434	0815-0003	1	1		
R44	Same as R14						
R45	Resistor: fixed, wirewound, 3000 ohms $\pm 10\%$, 10 W	35434	0816-0002	1	1		
R46 thru R56	Not assigned						
R57	Resistor: fixed, composition, 470 ohms $\pm 10\%$, 1 W	01121	0690-4711	1	1		
R58, 59	Resistor: fixed, deposited carbon, 53.3 ohms $\pm 1\%$, 1/8 W part of Attenuator Assembly	19701	0721-0006	2	1		
R60	Resistor: fixed, composition, 120 ohms $\pm 10\%$, 1/5 W Optimum value selected at factory Average value shown	10646	0681-0005	1	1		
R61	Same as R7						
R62	Resistor: variable, composition, 25,000 ohms $\pm 20\%$, 1 W	71590	2100-0009	1	1		
R63, 64	Not assigned						
R65	Resistor: fixed, composition, 12,000 ohms $\pm 10\%$, 1 W	01121	0690-1231	1	1		
R66	Same as R9						
R67	Resistor: fixed, composition, 1.8 megohms $\pm 10\%$, 1 W	01121	0690-1851	1	1		
R68	Same as R8						
R69	Same as R11						

* Refer to "List of Manufacturers' Codes".

TQ Total Quantity used in the instrument.

RS Recommended spares for one year isolated service for one instrument.

TABLE OF REPLACEABLE PARTS

Circuit Ref.	Description	Mfr. *	Stock No.	TQ	RS		
R70	Same as R9						
R71	Resistor: variable, composition, 50,000 ohms $\pm 20\%$, 1/3 W	71450	2100-0157	2	1		
R72	Resistor: fixed, composition, 220,000 ohms $\pm 10\%$, 1 W	01121	0690-2241	3	1		
R73	Resistor: fixed, composition, 27,000 ohms $\pm 10\%$, 1 W	01121	0690-2731	1	1		
R74	Resistor: fixed, composition, 68,000 ohms $\pm 10\%$, 2 W	01121	0693-6831	1	1		
R75	Resistor: fixed, composition, 33,000 ohms $\pm 10\%$, 1 W	01121	0690-3331	3	1		
R76	Same as R11						
R77	Same as R8						
R78	Same as R11						
R79	Same as R72						
R80	Same as R71						
R81	Same as R72						
R82	Not assigned						
R83	Same as R75						
R84, 85	Resistor: fixed, composition, 68,000 ohms $\pm 10\%$, 1 W	01121	0690-6831	2	1		
R86	Same as R75						
R87	Resistor: variable, composition, linear taper, 1500 ohms $\pm 10\%$	01121	2100-0025	1	1		
R88	Resistor: fixed, composition, 470,000 ohms $\pm 10\%$, 1/2 W	01121	0687-4741	2	1		
R89	Same as R16						
R90, 91	Resistor: fixed, composition, 82 ohms $\pm 10\%$, 1 W	01121	0690-8201	2	1		
R92	Same as R28						
R93	Resistor: fixed, composition, 82,000 ohms $\pm 10\%$, 1 W	01121	0690-8231	2	1		

* Refer to "List of Manufacturers' Codes".

TQ Total Quantity used in the instrument.

RS Recommended spares for one year isolated service for one instrument.

TABLE OF REPLACEABLE PARTS

Circuit Ref.	Description	Mfr. *	Stock No.	TQ	RS		
R94	Same as R88						
R95	Same as R16						
R96	Resistor: fixed, composition, 150 ohms $\pm 10\%$, 1 W	01121	0690-1511	1	1		
R97	Same as R28						
R98	Same as R93						
R99	Resistor: fixed, composition, 1800 ohms $\pm 10\%$, 1 W	01121	0690-1821	1	1		
R100	Resistor: fixed, composition, 10 megohms $\pm 10\%$, 1 W	01121	0690-1061	1	1		
R101	Same as R11						
R102	Same as R28						
R103	Not assigned						
R104	Resistor: variable, composition, linear taper, 10,000 ohms $\pm 20\%$, 1/2 W	71450	2100-0156	2	1		
R105	Resistor: fixed, composition, 220 ohms $\pm 10\%$, 1 W	01121	0690-2211	1	1		
R106	Same as R104						
R107	Same as R28						
R108	Resistor: fixed, composition, 27 ohms $\pm 10\%$, 1/5 W	10646	0681-0001	2	1		
R109	Resistor: fixed, composition, 100 ohms $\pm 10\%$, 1/5 W	10646	0681-0004	1	1		
R110	Resistor: fixed, composition, 47 ohms $\pm 10\%$, 1/5 W	10646	0681-0002	2	1		
R111	Resistor: fixed, composition, 150 ohms $\pm 10\%$, 1/5 W	10646	0681-0006	2	1		
R112	Same as R108						
R113	Same as R111						
R114	Resistor: fixed, 1000 ohms Part of FL9						
R115	Same as R110						

* Refer to "List of Manufacturers' Codes".

TQ Total Quantity used in the instrument.

RS Recommended spares for one year isolated service for one instrument.

TABLE OF REPLACEABLE PARTS

Circuit Ref.	Description	Mfr. *	Stock No.	TQ	RS		
R116 thru R118	Not assigned						
R119	Same as R10						
R120	Resistor: fixed, composition, 1000 ohms $\pm 10\%$, 2 W	01121	0693-1021	1	1		
R121 thru R123	Not assigned						
R124	Resistor: fixed, wirewound, 60 ohms $\pm 5\%$, 4 W	35434	0818-0027	1	1		
R125	Resistor: fixed, wirewound, 100 ohms $\pm 10\%$, 20 W	35434	0819-0019	1	1		
S1	Switch, rotary: 5 position	76854	3100-0097	1	1		
S2	Not assigned						
S3	Switch, toggle: DPST	04009	3101-0003	1	1		
T1	Transformer, power	28480	9100-0047	1	1		
T2	Transformer, audio: RF Generator Heater Supply	28480	9120-0022	1	1		
V1	Tube, electron: 6BQ7A	86684	1932-0021	1	1		
V2	Tube, electron: 12AU7	33173	1932-0029	2	2		
V3, 4, 5	Tube, electron: 6CL6	82219	1923-0030	3	3		
V6	Tube, electron: 5675	86684	1921-0001	1	1		
V7	Not assigned						
V8	Tube, electron: 5876	86684	1921-0002	1	1		
V9 thru V11	Not assigned						
V12	Tube, electron: 6AU6	86684	1923-0021	2	2		
V13	Tube, electron: 6080	86684	1932-0010	2	2		
V14	Same as V12						
V15	Tube, electron: 5651	86684	1940-0001	1	1		

* Refer to "List of Manufacturers' Codes".

TQ Total Quantity used in the instrument.

RS Recommended spares for one year isolated service for one instrument.

TABLE OF REPLACEABLE PARTS

Circuit Ref.	Description	Mfr. *	Stock No.	TQ	RS		
V16	Same as V13						
V17	Tube, electron: 7119	73445	1932-0016	1	1		
V18,19	Tube, electron: 6AH6	33173	1923-0017	2	2		
V20	Tube, electron: 6AL5	33173	1930-0013	1	1		
V21	Same as V2						
	<u>MISCELLANEOUS</u>						
	Attenuator, knob and dial assembly	28480	608C-40A	1	1		
	Attenuator, drive pulley	28480	608D-34F	1	1		
	Attenuator drive cable: 36 in. long	28480	G-18B	1	1		
	Body, oscillator, tube socket	28480	608D-59A-3	1	1		
	Power monitor assembly	28480	608D-95A	1	1		
	Capacitor Assembly, attenuator	28480	608A-95B	1	1		
	Cam, frequency adjust	28480	608D-59H	1	1		
	Clip, for Power Monitor rectifier	28480	608A-28C	1	1		
	Contact Assembly: for oscillator pick-up coil	28480	608D-100K	1	1		
	Center, contact, female, for output connector	91737	1250-0017	1	1		
	Contact, oscillator grid	28480	608A-100V	1	1		
	Contact, oscillator tube socket	28480	608D-59A-2	1	1		
	Contact, amplifier cathode	28480	608A-100W	1	1		
	Crank, handle	28480	G-74AE	1	1		
	Coupler, flexible, bellows type	28480	G-32K	1	1		
	Detent arm, range switch	28480	608D-59C	1	1		
	Fuseholder	75915	1400-0007	2	1		
	Gear, frequency stop	28480	G-24C-2	1	1		
	Gear, worm, oscillator drive	28480	608D-24A	1	1		

* Refer to "List of Manufacturers' Codes".

TQ Total Quantity used in the instrument.

RS Recommended spares for one year isolated service for one instrument.

TABLE OF REPLACEABLE PARTS

Circuit Ref.	Description	Mfr. *	Stock No.	TQ	RS		
	Gear, frequency drive	28480	608D-37B	1	1		
	Holder, lamp (I1)	95263	1450-0013	1	1		
	Holder, lamp (I3)	95263	1450-0012	1	1		
	Holder, lamp (panel)	72619	1450-0027	1	1		
	Insulator, card, attenuator	28480	608A-34C	1	1		
	Insulator, standoff, cylindrical shape	72656	0340-0020	2	1		
	Insulator, shoulder bushing	72656	0340-0005	2	1		
	Insulator, standoff, cylindrical shape, 1/2 in. long x 1/2 in. dia.	71590	0340-0007	1	1		
	Insulator, standoff, .625 in. long	71590	0340-0006	8	2		
	Knob: OUTPUT LEVEL	28480	G-74B	1	1		
	Knob: OUTPUT LEVEL, skirted	28480	G-74L	1	1		
	Knob: FINE FREQ. ADJUST	28480	G-74D	1	1		
	Knob: MOD. LEVEL AMP TRIMMER	28480	G-74F	2	1		
	Knob: MOD. SELECTOR, FREQ. RANGE	28480	G-74N	1	1		
	Roller, detent	28480	608D-59D	1	1		
	Spring, lock	28480	1460-0013	1	1		
	Screw, captive, for cabinet with knurled head	28480	608D-44K	1	1		
	Spacer, bakelite oscillator tube	28480	608D-59A-4	1	1		
	Spring, detent	28480	608D-59C	1	1		
	Shaft, amplifier drive	28480	608D-37A	1	1		
	Shaft, frequency vernier, bakelite	28480	608D-37F	1	1		
	Socket, for Power Monitor crystals	28480	608A-28D	1	1		
	Socket, for pencil triode filament	28480	1200-0010	1	1		

* Refer to "List of Manufacturers' Codes".

TQ Total Quantity used in the instrument.

RS Recommended spares for one year isolated service for one instrument.

TABLE OF REPLACEABLE PARTS

Circuit Ref.	Description	Mfr. *	Stock No.	TQ	RS		
	Turret Assembly: Amplifier	28480	608C-60A	1	1		
	Turret Assembly: Oscillator	28480	608C-60B	1	1		
	Wrench, spanner	28480	612A-38A	1	1		
	Window, dial: for attenuator dial	28480	G-99M	1	1		
	Window, frequency dial	28480	608C-83C	1	1		

* Refer to "List of Manufacturers' Codes".

TQ Total Quantity used in the instrument.

RS Recommended spares for one year isolated service for one instrument.

LIST OF MANUFACTURERS

The following code numbers are from the Federal Supply Code for Manufacturers Cataloging Handbooks H4-1 (Name to Code) and H4-2 (Code to Name) and their latest supplements. The date of revision and the date of the supplements used appear at the bottom of each page. Alphabetical codes have been arbitrarily assigned to suppliers not appearing in the H4 handbooks.

CODE NO.	MANUFACTURER	ADDRESS	CODE NO.	MANUFACTURER	ADDRESS	CODE NO.	MANUFACTURER	ADDRESS
00334	Humidial Co.	Colton, Calif.	19500	Thomas A. Edison Industries, Div. of McGraw-Edison Co.	West Orange, N.J.	72619	Dialight Corp.	Brooklyn, N.Y.
00335	Westrex Corp.	New York, N.Y.				72656	General Ceramics Corp.	Keasbey, N.J.
00656	Aerovox Corp.	New Bedford, Mass.	19701	Electra Manufacturing Co.	Kansas City, Mo.	72758	Girard-Hopkins	Oakland, Calif.
00781	Aircraft Radio Corp.	Boonton, N.J.	20183	Electronic Tube Corp.	Philadelphia, Pa.	72765	Drake Mfg. Co.	Chicago, Ill.
00853	Sangamo Electric Co., Cap. Div.	Marion, Ill.	21520	Fansteel Metallurgical Corp.	No. Chicago, Ill.	72825	Hugh H. Eby Inc.	Philadelphia, Pa.
00891	Carl E. Holmes Corp.	Los Angeles, Calif.	21335	The Fafnir Bearing Co.	New Britain, Conn.	72928	Gudeman Co.	Chicago, Ill.
01121	Allen Bradley Co.	Milwaukee, Wis.	21964	Fed. Telephone and Radio Corp.	Clifton, N.J.	72982	Erie Resistor Corp.	Erie, Pa.
01255	Litton Industries, Inc.	Beverly Hills, Calif.	24446	General Electric Co.	Schenectady, N.Y.	73061	Hansen Mfg. Co., Inc.	Princeton, Ind.
01281	Pacific Semiconductors, Inc.	Culver City, Calif.	24455	G. E., Lamp Division	Nela Park, Cleveland, Ohio	73138	Helipot Div. of Beckman Instruments, Inc.	Fullerton, Calif.
01295	Texas Instruments, Inc. Semiconductor Components Div.	Dallas, Texas	24655	General Radio Co.	West Concord, Mass.	73293	Hughes Products Div. of Hughes Aircraft Co.	Newport Beach, Calif.
01349	The Alliance Mfg. Co.	Alliance, Ohio	26462	Grobet File Co. of America, Inc.	Carlstadt, N.J.	73445	Amperex Electronic Co., Div. of North American Phillips Co., Inc.	Hicksville, N.Y.
02114	Ferroxcube Corp. of America	Saugerties, N.Y.	26992	Hamilton Watch Co.	Lancaster, Pa.	73506	Bradley Semiconductor Corp.	New Haven, Conn.
02286	Cole Mfg. Co.	Palo Alto, Calif.	28480	Hewlett-Packard Co.	Palo Alto, Calif.	73559	Carling Electric, Inc.	Hartford, Conn.
02660	Amphenol Electronics Corp.	Chicago, Ill.	33173	G. E. Receiving Tube Dept.	Owensboro, Ky.	73682	George K. Garrett Co., Inc.	Philadelphia, Pa.
02735	Radio Corp. of America Semiconductor and Materials Div.	Somerville, N.J.	35434	Lectrohm Inc.	Chicago, Ill.	73743	Fischer Special Mfg. Co.	Cincinnati, Ohio
02777	Hopkins Engineering Co.	San Francisco, Calif.	37942	P. R. Mallory & Co., Inc.	Indianapolis, Ind.	73793	The General Industries Co.	Elyria, Ohio
03508	G.E. Semiconductor Products Dept.	Syracuse, N.Y.	39543	Mechanical Industries Prod. Co.	Akron, Ohio	73905	Jennings Radio Mfg. Co.	San Jose, Calif.
03705	Apex Machine & Tool Co.	Dayton, Ohio	40920	Miniature Precision Bearings, Inc.	Keene, N.H.	74455	J. H. Winns, and Sons	Winchester, Mass.
03797	Eldema Corp.	El Monte, Calif.	42190	Muter Co.	Chicago, Ill.	74861	Industrial Condenser Corp.	Chicago, Ill.
04009	Arrow, Hart and Hegeman Elect. Co.	Hartford, Conn.	44655	Ohmite Mfg. Co.	Skokie, Ill.	74868	Industrial Products Co.	Danbury, Conn.
04222	Hi-Q Division of Aerovox	Myrtle Beach, S.C.	48620	Precision Thermometer and Inst. Co.	Philadelphia, Pa.	74970	E. F. Johnson Co.	Waseca, Minn.
04404	Dymec Inc.	Palo Alto, Calif.	54294	Shallcross Mfg. Co.	Selma, N.C.	75042	International Resistance Co.	Philadelphia, Pa.
04651	Special Tube Operations of Sylvania Electronic Systems	Mountain View, Calif.	55933	Sonotone Corp.	Elmsford, N.Y.	75378	James Knights Co.	Sandwich, Ill.
04713	Motorola, Inc., Semiconductor Prod. Div.	Phoenix, Arizona	55938	Sorenson & Co., Inc.	So. Norwalk, Conn.	75382	Kulka Electric Mfg. Co., Inc.	Mt. Vernon, N.Y.
04777	Automatic Electric Sales Corp.	Northlake, Ill.	56137	Spaulding Fibre Co., Inc.	Tonawanda, N.Y.	75818	Lenz Electric Mfg. Co.	Chicago, Ill.
05624	Barber Colman Co.	Rockford, Ill.	56289	Sprague Electric Co.	North Adams, Mass.	75915	Littlefuse Inc.	Des Plaines, Ill.
05783	Stewart Engineering Co.	Soquel, Calif.	61775	Union Switch and Signal, Div. of Westinghouse Air Brake Co.	Pittsburgh, Pa.	76005	Lord Mfg. Co.	Erie, Pa.
06004	The Bassick Co.	Bridgeport, Conn.	62119	Universal Electric Co.	Owosso, Mich.	76210	C. W. Marwedel	San Francisco, Calif.
06812	Torrington Mfg. Co., West. Div.	Van Nuys, Calif.	64959	Western Electric Co., Inc.	New York, N.Y.	76433	Micamold Electronic Mfg. Corp.	Brooklyn, N.Y.
07115	Corning Glass Works Electronic Components Dept.	Bradford, Pa.	65092	Weston Inst. Div. of Daystrom, Inc.	Newark, N.J.	76487	James Millen Mfg. Co., Inc.	Malden, Mass.
07261	Avnet Corp.	Los Angeles, Calif.	70119	Advance Electric and Relay Co.	Burbank, Calif.	76530	Monadnock Mills	San Leandro, Calif.
07263	Fairchild Semiconductor Corp.	Mountain View, Calif.	70276	Allen Mfg. Co.	Hartford, Conn.	76545	Mueller Electric Co.	Cleveland, Ohio
07933	Rheem Semiconductor Corp.	Mountain View, Calif.	70309	Allied Control Co., Inc.	New York, N.Y.	76854	Oak Manufacturing Co.	Chicago, Ill.
07980	Boonton Radio Corp.	Boonton, N.J.	70563	Amperite Co., Inc.	New York, N.Y.	77068	Bendix Corp., Bendix Pacific Div.	No. Hollywood, Calif.
08718	Cannon Electric Co. Phoenix Div.	Phoenix, Ariz.	70903	Belden Mfg. Co.	Chicago, Ill.	77221	Phaotron Instrument and Electronic Co.	South Pasadena, Calif.
08733	Camloc Fastener Corp.	Los Angeles, Calif.	70998	Bird Electronic Corp.	Cleveland, Ohio	77342	Potter and Brumfield, Inc.	Princeton, Ind.
08792	CBS Electronics Semiconductor Operations, Div. of C.B.S. Inc.	Lowell, Mass.	71002	Birnbach Radio Co.	New York, N.Y.	77630	Radio Condenser Co.	Camden, N.J.
09134	Texas Capacitor Co.	Houston, Texas	71218	Bud Radio Inc.	Cleveland, Ohio	77634	Radio Essentials Inc.	Mt. Vernon, N.Y.
09250	Electro Assemblies, Inc.	Chicago, Ill.	71286	Camloc Fastener Corp.	Paramus, N.J.	77638	Radio Receptor Co., Inc.	Brooklyn, N.Y.
10646	Carborundum Co.	Niagara Falls, N.Y.	71313	Allen D. Cardwell Electronic Prod. Corp.	Plainville, Conn.	77764	Resistance Products Co.	Harrisburg, Pa.
12697	Clarostat Mfg. Co.	Dover, N.H.	71400	Bussmann Fuse Div. of McGraw-Edison Co.	St. Louis, Mo.	78283	Signal Indicator Corp.	New York, N.Y.
14655	Cornell Dubilier Elec. Corp.	So. Plainfield, N.J.	71450	Chicago Telephone Supply Co.	Elkhart, Ind.	78471	Tilley Mfg. Co.	San Francisco, Calif.
15909	The Daven Co.	Livingston, N.J.	71468	Cannon Electric Co.	Los Angeles, Calif.	78488	Stackpole Carbon Co.	St. Marys, Pa.
16758	Delco Radio Div. of G. M. Corp.	Kokomo, Ind.	71471	Cinema Engineering Co.	Burbank, Calif.	79142	Veeder Root, Inc.	Hartford, Conn.
18873	E. I. DuPont and Co., Inc.	Wilmington, Del.	71482	C. P. Clare & Co.	Chicago, Ill.	79251	Wenco Mfg. Co.	Chicago, Ill.
19315	Eclipse Pioneer, Div. of Bendix Aviation Corp.	Teterboro, N.J.	71590	Centralab Div. of Globe Union Inc.	Milwaukee, Wis.	79963	Zierick Mfg. Corp.	New Rochelle, N.Y.
			71700	The Cornish Wire Co.	New York, N.Y.	80130	Times Facsimile Corp.	New York, N.Y.
			71744	Chicago Miniature Lamp Works	Chicago, Ill.	80248	Oxford Electric Corp.	Chicago, Ill.
			71753	A. O. Smith Corp., Crowley Div.	West Orange, N.J.	80411	Acro Manufacturing Co.	Columbus, Ohio
			71785	Cinch Mfg. Corp.	Chicago, Ill.	80486	All Star Products Inc.	Defiance, Ohio
			71984	Dow Corning Corp.	Midland, Mich.	80583	Hammerlund Co., Inc.	New York, N.Y.
			72136	Electro Motive Mfg. Co., Inc.	Willimantic, Conn.	80640	Stevens, Arnold, Co., Inc.	Boston, Mass.
						81030	International Instruments, Inc.	New Haven, Conn.
						81415	Wilkor Products, Inc.	Cleveland, Ohio
						81453	Raytheon Mfg. Co., Industrial Tube Division	Quincy, Mass.



WARRANTY

All our products are warranted against defects in materials and workmanship for one year from the date of shipment. Our obligation is limited to repairing or replacing products (except tubes) which prove to be defective during the warranty period. We are not liable for consequential damages.

For assistance of any kind, including help with instruments under warranty, contact your authorized  Sales Representative for instructions. Give full details of the difficulty and include the instrument model and serial numbers. Service data or shipping instructions will be promptly sent to you. There will be no charge for repair of instruments under warranty, *except transportation charges*. Estimates of charges for non-warranty or other service work will always be supplied, if requested, before work begins.

CLAIM FOR DAMAGE IN SHIPMENT

Your instrument should be inspected and tested as soon as it is received. The instrument is insured for safe delivery. If the instrument is damaged in any way or fails to operate properly, file a claim with the carrier or, if insured separately, with the insurance company.

SHIPPING

On receipt of shipping instructions, forward the instrument prepaid to the destination indicated. You may use the original shipping carton or any strong container. Wrap the instrument in heavy paper or a plastic bag and surround it with three or four inches of shock-absorbing material to cushion it firmly and prevent movement inside the container.

GENERAL

Your authorized  Sales Representative is ready to assist you in any situation, and you are always welcome to get directly in touch with Hewlett-Packard service departments:

CUSTOMER SERVICE

Hewlett-Packard Company
395 Page Mill Road
Palo Alto, California, U.S.A.
Telephone: DAvenport 6-1755
Direct Dial Area Code 415
TWX No. PAL AL 117-U
Cable: "HEWPACK"

OR (In Western Europe)

Hewlett-Packard S.A.
Rue du Vieux Billard No. 1
Geneva, Switzerland
Telephone: (022) 26. 43. 36
Cable: "HEWPACKSA"



